

General characteristics

No. of poles	2 Form Z
Volume	3.3 cm ³ [1.03 in ³]
Mass	77 grams [1.17 lb. Max]

Switching characteristics

Operate time @ 25° C with DC coil (Latch & Reset)	15 ms max.
Bounce time @ 25° C	5 ms max.
Mechanical Life	400,000 cycles

Contact rating	Type of load (High level)	Cycles x 10 ³	28 Vdc	115 Vac	115 Vac	115/200 Vac	115/200 Vac
				400 Hz 1 phase	50/60 Hz 1 phase	400 Hz 3 phase	50/60 Hz 3 phase
	Resistive	100	15 amps	15 amps	9 amps	15 amps	9 amps
	Inductive	20	15 amps	15 amps	n/a	15 amps	n/a
	Inductive	10	n/a	n/a	9 amps	n/a	9 amps
	Motor	100	10 amps	10 amps	5 amp	10 amps	5 amps
	Lamp	100	5 amps	5 amps	3 amps	n/a	n/a
	Overload current	n/a	40 amps	60 amps	n/a	60 amps	n/a
	Rupture current	n/a	50 amps	80 amps	n/a	80 amps	n/a

Environmental characteristics

Temperature Range	-70°C to +125°C
Vibration (Sinusoidal)	30 g 10-3000 Hz
Mounting Style 3	20 g 57-3000 Hz
Shock, any axis	200 g 6 ms
Mounting Style 3	100 g 6 ms
Seal	Hermetic (1 x 10 ⁻⁸ atm cm ³ /s)

Electrical characteristics

Contact voltage drop (@ Rated resistive load)	
- Initial	150 mV Max.
- After guaranteed life	175 mV Max.

Dielectric strength @ sea level	Coil to Case	All other points
	1250 Vrms	1250 Vrms
- Initial @ 60Hz	1250 Vrms	1250 Vrms
- After guaranteed life @ 60 Hz	1250 Vrms	1250 Vrms

Insulation Resistance	
- Initial	1000 Megohms min. @ 500 Vdc
- After life tests	500 Megohms min. @ 500 Vdc

Reference Military Specifications	MIL-PRF-83536
-----------------------------------	---------------

EDL S 2 A 2 A D

RELAY TYPE

'EDL' = Double Break Latching

OPTIONAL

'S' Internal Voltage suppressor
'R' Internal Voltage suppressor

MODEL

2: 2 FORM Z 15 Amps

COIL CODE

2: See Page 28

MOUNTING STYLES

2: See Page 29 - 30

TERMINAL STYLE AND FINISH

2: See Page 31

'D' FOR CATALOG STANDARD OR
'A' FOR CATALOG STANDARD WITHOUT ARC BARRIERS OR
'XXXX' FOR SPECIAL INSTRUCTIONS OR SPECIFICATIONS
(ASSIGNED BY DRI)

Coil Characteristics

COIL CODE	DC					
	A	B	D	E	G	J
Nominal coil voltage	6	12	26,5	28	48	110
Maximum latch & reset voltage at 25°C	3	6	13,5	14	24	55
Maximum latch & reset voltage at 125°C	3,9	7,7	18	18	31	70
Coil resistance (ohms $\pm 10\%$ at 25 C)	18	70	290	290	955	5000
Maximum coil transient suppression (where applicable) VDC	See	circuit	diagram	below	100	180

OTHER VOLTAGES AVAILABLE FROM FACTORY ON REQUEST

Circuit Diagram

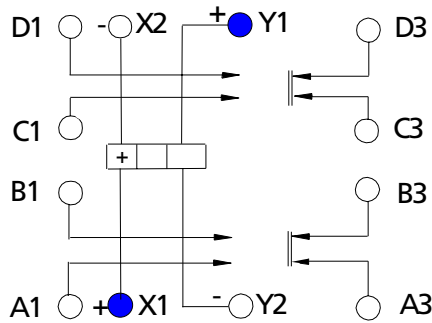

EDL2
Y1 - COIL
LAST ENERGIZED

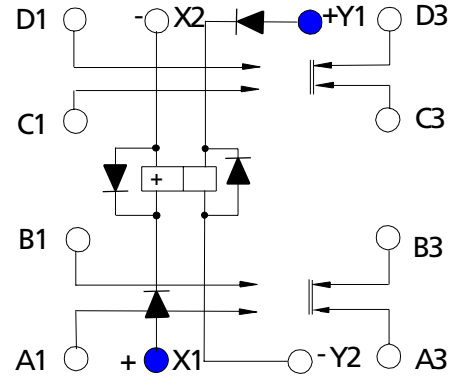

EDLR2
Y1 - COIL LAST ENERGIZED*
WITH OPTIONAL INTERNAL
VOLTAGE SUPPRESSOR
(-5 Vdc MAX.)

EDLS2
Y1 - COIL
LAST ENERGIZED
OPTIONAL INTERNAL
VOLTAGE SUPPRESSOR
(-42 Vdc MAX.)

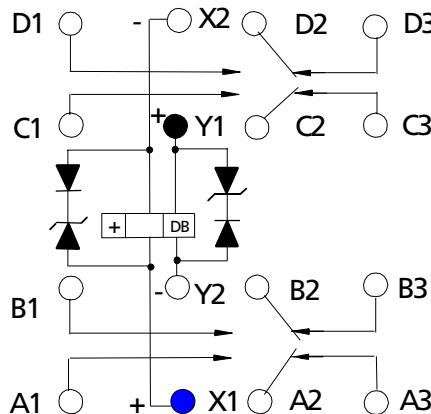

■ Mounting styles

DIMENSIONS ARE IN MM (IN.)
UNLESS OTHERWISE SPECIFIED, TOLERANCE IS $\pm 0,25$ [.010]

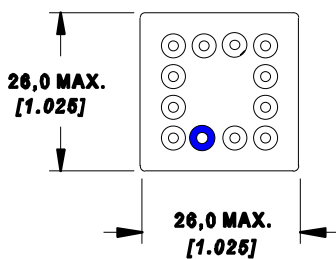
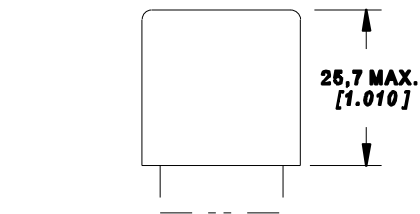

STYLE 1
NO MOUNT

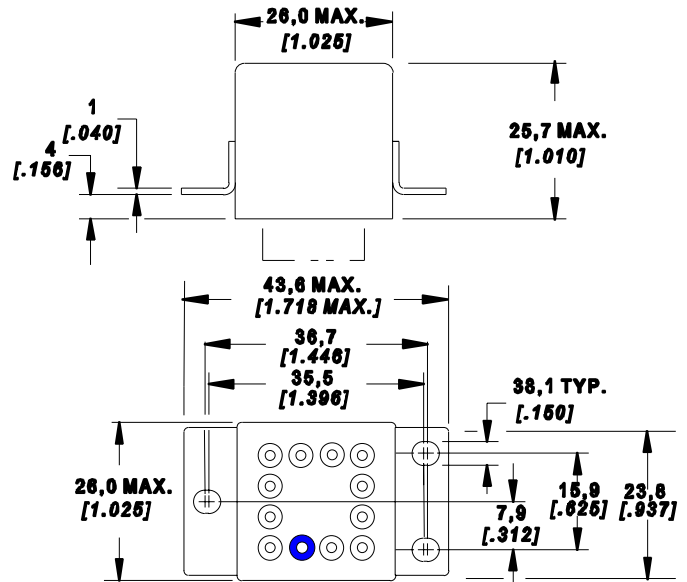

STYLE 2
RAISED VERTICAL FLANGE MOUNT

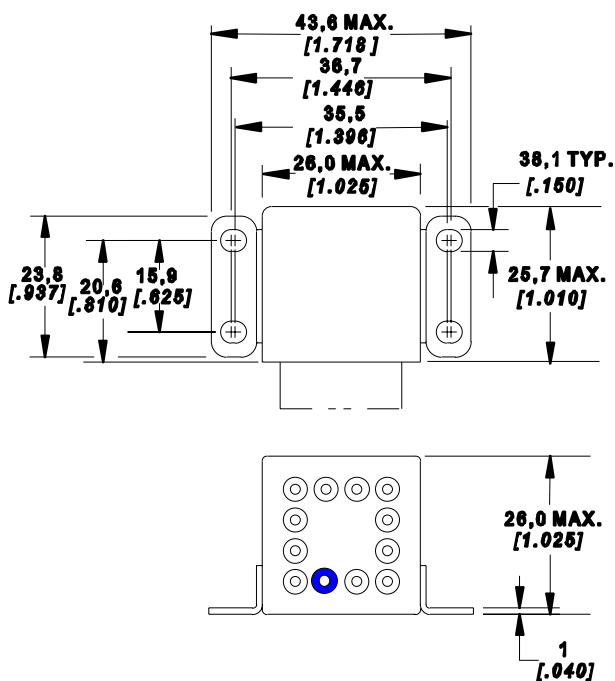

STYLE 3
HORIZONTAL FLANGE MOUNT

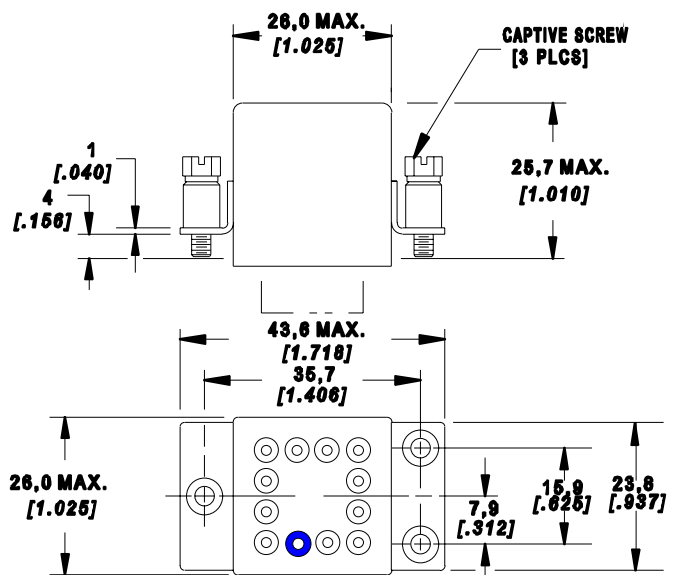

STYLE 8: M3 CAPTIVE SCREWS
STYLE C: #4-40 UNC CAPTIVE SCREWS
RAISED VERTICAL FLANGE MOUNT
WITH CAPTIVE HARDWARE

Mounting styles

DIMENSIONS ARE IN MM (IN.)
UNLESS OTHERWISE SPECIFIED, TOLERANCE IS $\pm 0,25$ [.010]

STYLE G

RAISED VERTICAL FLANGE MOUNT WITH CAPTIVE HARDWARE

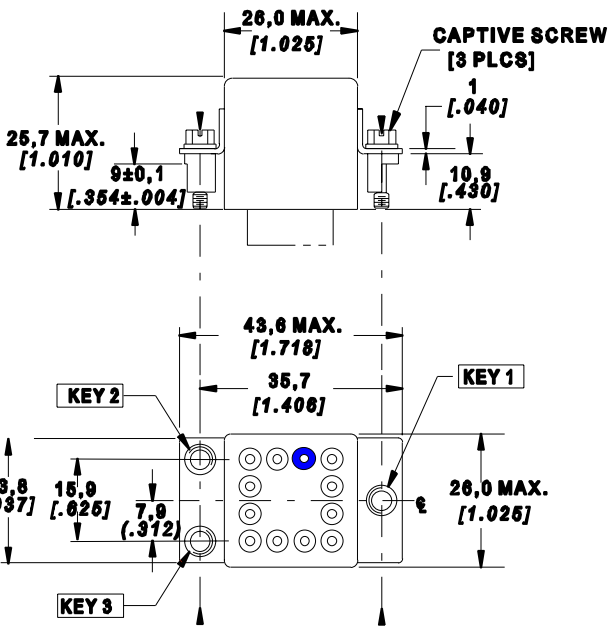
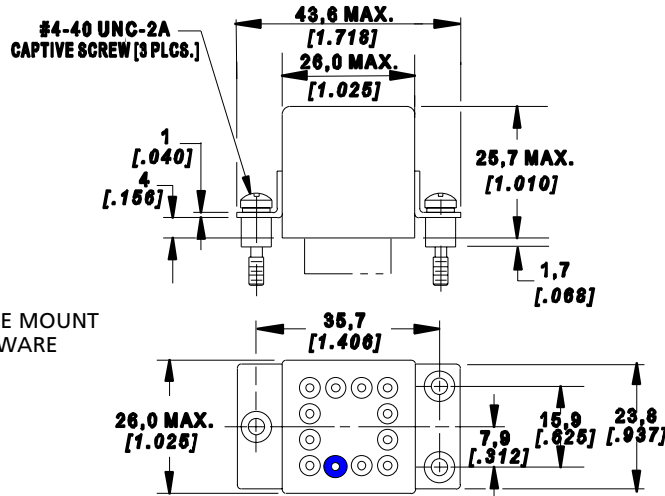

KEYING SYSTEM WITH CAPTIVE HARDWARE

STYLE A: M3 CAPTIVE SCREWS

STYLE B: #4-40 UNC CAPTIVE SCREWS

KEYING POSITIONS

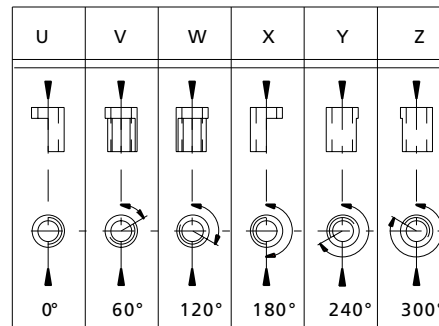

	COIL	KEY 1	KEY 2	KEY 3
SUPPRESSED	6 VDC	V	Z	V
	12 VDC	X	Z	V
	26.5 VDC	Z	X	U
	28 VDC	Z	X	V
	48 VDC	V	Z	U
	110 VDC	X	Z	U
	6 VDC	V	Z	X
	12 VDC	X	Z	X
	26.5 VDC	Z	X	W
	28 VDC	Z	X	Y
48 VDC	V	Z	W	
110 VDC	X	Z	W	

KEYING CONFIGURATION SHOWN IN TABLE COMES STANDARD WITH SPECIFIED COIL VOLTAGE. FOR ORDERING OTHER KEYING POSITIONS USE 3 DIGIT (XXX) "SPECIAL INSTRUCTIONS" ON END OF P/N.
EX: EDL2ABCXYZ

Termination styles

DIMENSIONS ARE IN MM (IN.)
UNLESS OTHERWISE SPECIFIED, TOLERANCE IS $\pm 0,25$ [.010]

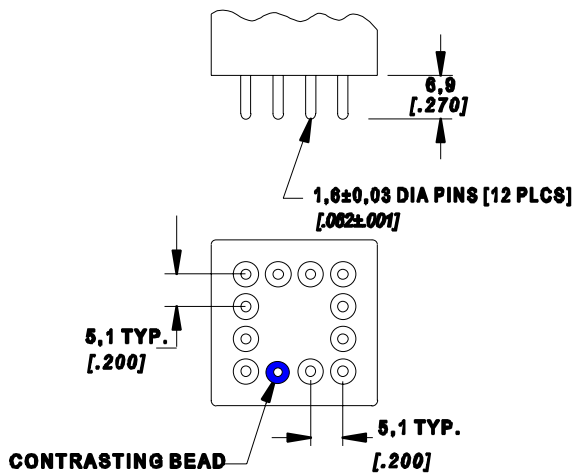

SOLDER PIN

STYLE A: TIN PLATED
STYLE B: SOLDER DIPPED

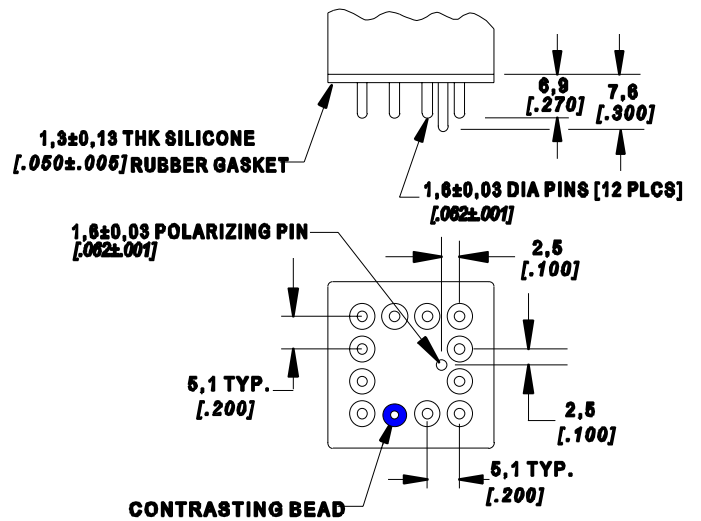

PLUG IN

STYLE M: GOLD PLATED WITH TIN PLATED
POLARIZING PINS

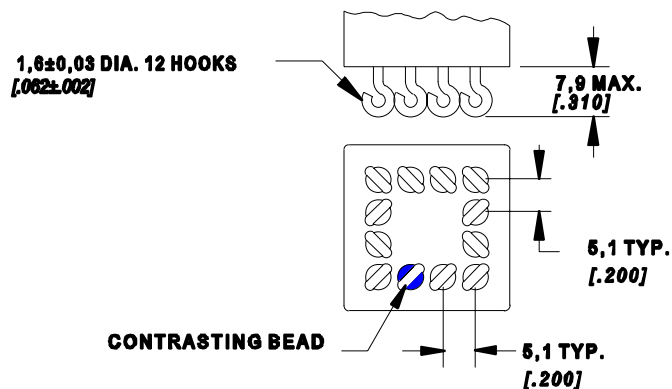

SOLDER HOOK

STYLE H: TIN PLATED
STYLE J: SOLDER DIPPED