

Property of  
Sensata Technologies

ZONE	REV.	REVISION DESCRIPTION	ECN NO.	DATE
C4 D3 C2	E	RE-DOCUMENTED IN SOLIDWORKS; ADDED "Ø" SYMBOL TO DIMENSION .213 ± .007; ADDED "R" TO DIMENSION .213 ± .015; ADDED PART NO. 4BTR2-*-** & 4BTD2-*-**; "L" WAS "DESIGNATES OPEN ON TEMPERATURE RISE." "F" WAS "DESIGNATES CLOSE ON TEMPERATURE RISE." ADDED "R" & "D" INFO; GML	ECO-073243	08-FEB-2012

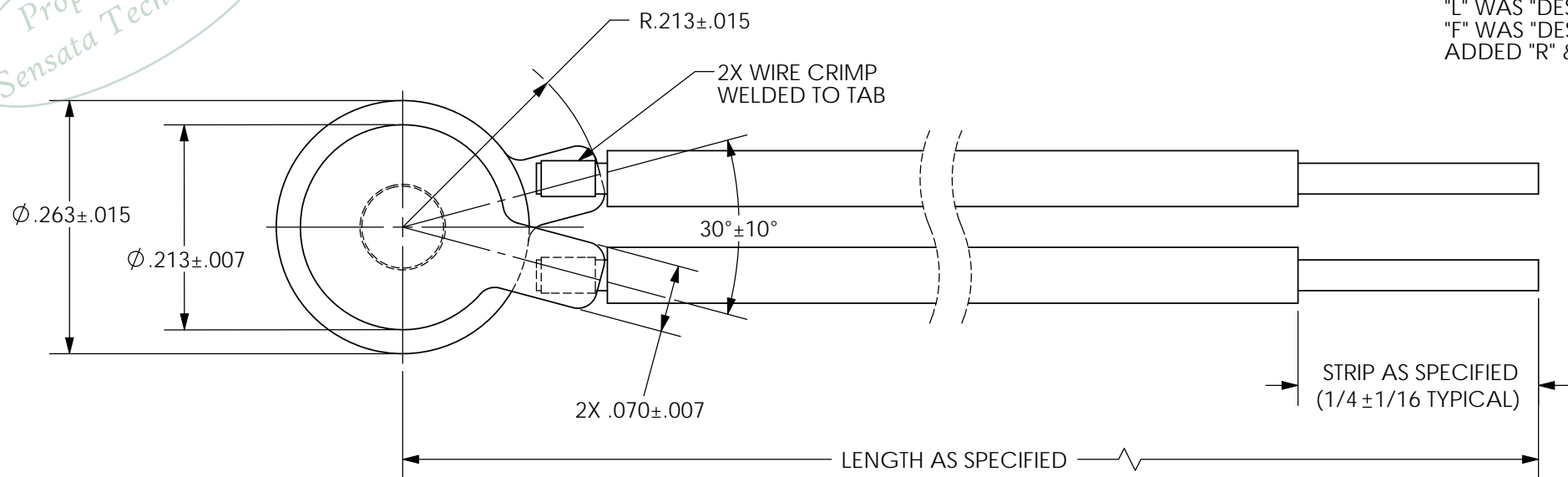



PART NO.: 4BTL2-\*-\*\*  
4BTR2-\*-\*\*  
4BTF2-\*-\*\*  
4BTD2-\*-\*\*

"L" DESIGNATES OPEN ON TEMPERATURE RISE, SILVER CONTACTS.  
"R" DESIGNATES OPEN ON TEMPERATURE RISE, GOLD CONTACTS.  
"F" DESIGNATES CLOSE ON TEMPERATURE RISE, SILVER CONTACTS.  
"D" DESIGNATES CLOSE ON TEMPERATURE RISE, GOLD CONTACTS.

\* WHEN CUSTOMERS TEMPERATURE CHARACTERISTICS ARE ESTABLISHED A DASH NO. WILL BE ASSIGNED, THEREBY COMPLETING THE PART NO.

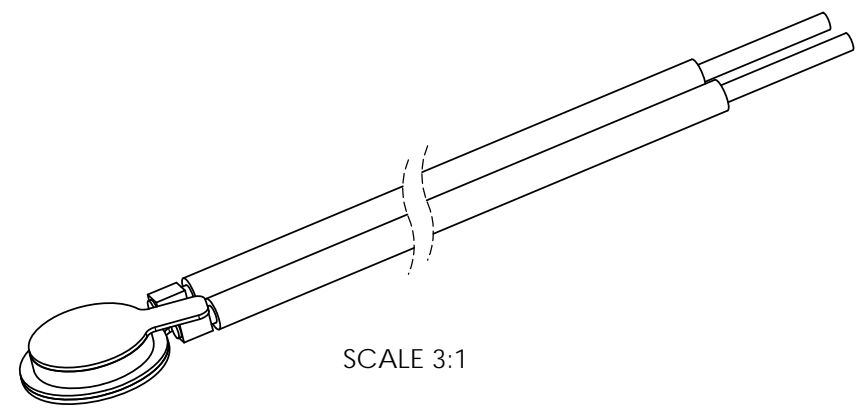
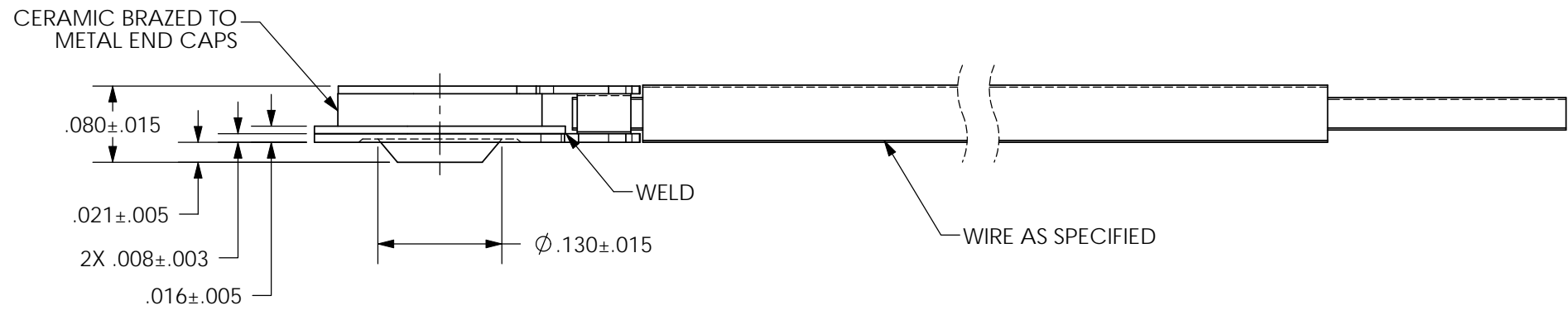
\*\* IF WIRE LEADS ARE REQUIRED A SECOND DASH NO. WILL BE ASSIGNED TO THE COMPLETED PART NO.



FOR REFERENCE ONLY, CHECK LATEST REVISION BEFORE USE. PARTS MADE TO THIS PRINT MUST CONFORM TO E9898 REV. E.		 529 PLEASANT STREET P.O. BOX 2964 ATTLEBORO, MA 02703
DRAWN J.D.MAYALL DATE 04-JAN-1964	SENSATA TECHNOLOGIES PROPRIETARY AND CONFIDENTIAL. NEITHER THIS PRINT NOR THE INFORMATION CONTAINED HEREON IS TO BE USED AGAINST THE INTERESTS OF SENSATA TECHNOLOGIES OR AGAINST THE INTERESTS OF ANY OF ITS AFFILIATED COMPANIES OR WHOLLY OWNED SUBSIDIARIES.	
ENGINEER L.MARCOUX DATE 06-JAN-1964	INTERPRET DIMENSIONING AND TOLERANCING PER ASME Y14.5-2009. UNLESS OTHERWISE SPECIFIED DIMENSIONS ARE IN INCHES. TOLERANCES DECIMALS                  ANGLES	TITLE 4BT-2 THERMOSTAT S.P.S.T. AUTO RESET SEALED ENVELOPE DRAWING
APPROVED		SIZE    DWG NO.                  REV. B                  4BT-2                                  E
DATE	DO NOT SCALE DRAWING    THIRD ANGLE PROJECTION	SCALE 6:1    SOLIDWORKS    SHEET 1 OF 1