

**EATON**

**Aerospace**

**Electric Distribution & Controls**

Circuit Breakers  
Military/Aerospace



## Table of Contents

<b>3</b>	Table of Contents
<b>4</b>	Descriptive Index
<b>5</b>	Fast Information Finder
<b>5</b>	Part Number to Page Index
<b>Capabilities and Product Overview</b>	
<b>6-7</b>	Circuit Breaker Product Overview
<b>8-9</b>	Organizational Capabilities
<b>10</b>	Arc Fault Circuit Interrupt (AFCI) Technology
<b>11</b>	Notes
<b>Single Phase, Thermal Circuit Breakers</b>	
<b>12-13</b>	Series 160 - 50 to 100A
<b>14-15</b>	Series 170 - 125 to 200A
<b>16-17</b>	Series 700 - 5 to 50A
<b>18-19</b>	Series 1500 - ½ to 10A
<b>20-21</b>	Series 4001 - 1 to 25A
<b>22-23</b>	Series 4200 - 1 to 25A
<b>24-25</b>	Series 4310 - 1 to 25A
<b>Three Phase, Thermal Circuit Breakers</b>	
<b>26-27</b>	Series 940 - 50 to 100A
<b>28-29</b>	Series 1526 - 1 to 15A
<b>30-31</b>	Series 1536 - 5 to 50A
<b>32-33</b>	Series 4330 - 1 to 20A
<b>Remote Controlled Circuit Breakers</b>	
<b>34-37</b>	Remote Controlled Circuit Breakers
<b>38-39</b>	Remote Power Controllers
<b>Additional Circuit Breaker Products</b>	
<b>40</b>	Additional Products
<b>Accessories</b>	
<b>40</b>	Rubber Boot Assembly
<b>Reference</b>	
<b>41</b>	Glossary
<b>42</b>	Military to Eaton Part Number Index

## Capabilities and Product Overview

## Single Phase, Circuit Breakers

## Three Phase, Circuit Breakers

## Remote Controlled Circuit Breakers

## Additional Circuit Breaker Products

## Accessories

## Reference

# Descriptive Index

<b>Accessories</b>	<b>40</b>	<b>Military Approved Devices</b>	
		160 Series	<b>12</b>
<b>AFCI</b>	<b>10</b>	170 Series	<b>14</b>
		700 Series	<b>16</b>
<b>Auxiliary Terminal</b>		4001 Series	<b>20</b>
4200 Series	<b>22</b>	4200 Series	<b>22</b>
RCCB	<b>34</b>	4310 Series	<b>24</b>
RPC	<b>38</b>	4330 Series	<b>32</b>
		RCCB	<b>34</b>
<b>Capabilities</b>	<b>8</b>		
		<b>Random Vibration</b>	
<b>Cross Reference</b>		700 Series	<b>16</b>
Part Number to Page	<b>5</b>	4001 Series	<b>20</b>
Military P/N to Eaton		4200 Series	<b>22</b>
Part Number	<b>42</b>		
		<b>Remote Controlled</b>	
<b>Fast-Trip (Load Protection)</b>		RCCB	<b>34</b>
1500 Series	<b>18</b>	RPC	<b>38</b>
1526 Series	<b>28</b>		
		<b>Single Phase</b>	
<b>High Vibration</b>		160 Series	<b>12</b>
160 Series	<b>12</b>	170 Series	<b>14</b>
700 Series	<b>16</b>	700 Series	<b>16</b>
4001 Series	<b>20</b>	1500 Series	<b>18</b>
4310 Series	<b>24</b>	4001 Series	<b>20</b>
4330 Series	<b>32</b>	4200 Series	<b>22</b>
		4310 Series	<b>24</b>
<b>Hot-wire</b>		RCCB	<b>34</b>
1500 Series	<b>18</b>		
1526 Series	<b>28</b>	<b>Temperature Compensated</b>	
		1500 Series	<b>18</b>
<b>Indicator Control Unit (ICU)</b>		1526 Series	<b>28</b>
1500 Series	<b>18</b>	1536 Series	<b>30</b>
		4310 Series	<b>24</b>
<b>Long Button</b>		4330 Series	<b>32</b>
700 Series	<b>16</b>		
4200 Series	<b>22</b>	<b>Three Phase</b>	
4310 Series	<b>24</b>	940 Series	<b>26</b>
4330 Series	<b>32</b>	1526 Series	<b>28</b>
		1536 Series	<b>30</b>
		4330 Series	<b>32</b>
		RCCB	<b>34</b>

## Find Information Fast

- **Have an Eaton part number and need more information?** Use the part number to page index on this page to get the exact page of the full product listing.
- **Have a Military part number and need applicable Eaton part number?** Use the Military part number Index in the back of this catalog.
- **Know the type of product you want, but not a specific part number?** Use the detailed Index on the facing page to find the section with those products or use the Product Overview for a quick side by side comparison.
- **Looking for a specific feature or attribute?** Use the Descriptive Index or Product Overview to quickly determine which products fit your application.
- **Need additional information not contained in this catalog?** For technical questions, application assistance, or the name of your local authorized distributor, call 1- 800-955-7354.





## Part Number to Page Index

Eaton Part No.	Page No.	Eaton Part No.	Page No.
60-	40	4330-	32
160-	12	4330-001-	32
160-012-	12	4330-007-	32
160-086-	12	4330-008-	32
100-	40	4330-009-	32
130-	40	4380-	40
140-	40	8500-	40
170-	14	9500-	40
170-001-	14	SM600BA -	34
180-	40	SM600BA125 (+)	38
260-	40	SM601BA -	34
270-	40		
700-	16		
700-001-	16		
700-089-	16		
700-092-	16		
780-	40		
920-	40		
930-	40		
940-	26		
940-006-	26		
960-	40		
970-	40		
1200-	40		
1500-	18		
1500-052-	18		
1526-	28		
1526-005-	28		
1536-	30		
1536-005-	30		
1538-	40		
1540-	40		
1585-	40		
2100-	40		
4001-	20		
4001-001-	20		
4001-008-	20		
4001-011-	20		
4200-	22		
4200-001-	22		
4200-003-	22		
4200-004-	22		
4200-006-	22		
4200-007-	22		
4310-	24		
4310-001-	24		
4310-005-	24		
4310-019-	24		
4310-024-	24		

# Circuit Breaker Product Overview

Please consult detailed product descriptions for more information.

## Single Phase

					
	<b>160 Series</b>	<b>170 Series</b>	<b>700 Series</b>	<b>1500 Series</b>	<b>4001 Series</b>
<b>Catalog Location</b>	pgs. 12-13	pgs. 14-15	pgs. 16-17	pgs. 18-19	pgs. 20-21
<b>MS Qualified</b>	MS25361	MS25017 <sup>(4)</sup>	MS25244 (MS25017) <sup>(4)</sup>	MS22074 <sup>(4)</sup>	MS22073
<b>Description</b>	Heavy-Duty, High Current Ratings	Heavy-Duty, Very High Current Ratings	Miniature, High Interrupting Capacity, Rugged Performer	Miniature, Fast-trip, Ambient Temperature Compensated	Sub-miniature, Precision, Lightweight
<b>Current Rating</b>	50 to 100 Amperes	125 to 200 Amperes	5 to 50 Amperes	0.5 to 10 Amperes	1 to 25 Amperes
<b>Voltage rating (For Interrupting Capacity)</b>	120 VAC, 400 Hz; 30 VDC	115 VAC, 400 Hz; 28 VDC	120 VAC, 400 Hz; 30 VDC	120 VAC, 400 Hz; 30 VDC	120 VAC, 400 Hz; 30 VDC
<b>Calibration @25° C (percent of amperage rating)</b>	105% Hold 138% within one hour	100% Hold 125% within one hour	115% Hold 138% within one hour	115% Hold 138% within one hour	115% Hold 150% within one hour
<b>Trip Time (in seconds at 25° C)</b>	All amperages	All amperages	All amperages	0.5-3A / 4.5-10A	All amperages
<b>200% Overload</b>	15.0 to 65.0	15.0 to 70.0	15.0 to 55.0	0.4 to 3.0 / 0.8 to 3.6	2.0 to 20.0
<b>500% Overload</b>	1.3 to 6.0 <sup>(2)</sup>	1.5 to 6.5 <sup>(2)</sup>	1.4 to 5.0 <sup>(2)</sup>	0.06 to 0.4 / 0.08 to 0.5 <sup>(2)</sup>	0.16 to 2.0
<b>1000% Overload</b>	0.5 to 2.0 <sup>(3)</sup>	0.5 to 2.5 <sup>(3)</sup>	0.5 to 1.5 <sup>(3)</sup>	0.02 to 0.18 / 0.02 to 0.2 <sup>(3)</sup>	0.046 to 0.5
<b>Interrupting Capacity (Rating Dependent)</b>	3500A @ 120V AC 6,000A @ 30V DC	2500A @ 115V AC 3,000A @ 28V DC	3500A @ 120V AC 6,000A @ 30V DC	600 to 1000A @ 120V AC 6,000A @ 30V DC	500 to 3500A @ 120V AC 2,000 to 6,000A @ 30V DC
<b>Weight g (lb.)</b>	113g (.250lb)	130g (.286lb)	43g (.095lb)	45g (.099 lb)	33g (.073 lb)
<b>Major Dimensions LxWxH (inches)</b>	2.250 x 1.812 x 0.750	2.250 x 1.812 x 1.00	1.860 x 1.094 x 0.750	1.843 x 1.137 x 0.750	1.852 x 0.703 x 0.593
<b>Notes</b>	MIL spec approved high vibration model.	Mounting dimensions compatible with Military Standard Drawing requirements of MS25017 of MIL-C5809.	Available with auxiliary switch. P-bracket allows variation of mounting. 40 & 50 ampere ratings not MIL spec approved.	Meets requirements for use as an RCCB ICU. I <sup>2</sup> t function is per specification.	Available in MIL spec approved high vibration and random vibration models and variations in termination and mounting. 25 ampere rating not MIL spec approved.

<sup>(1)</sup> Balanced, Unbalanced load 145%

<sup>(2)</sup> 400% Overload information available in detailed product listing

<sup>(3)</sup> 600% Overload information available in detailed product listing







<sup>(4)</sup> Designed to requirements of applicable specification. Contact Business Unit for details.

FOR CONFIGURATIONS NOT NOTED, CONTACT BUSINESS UNIT

# Circuit Breaker Product Overview

Please consult detailed product descriptions for more information.

## Three Phase

						
	<b>4200 Series</b>	<b>4310 Series</b>	<b>940 Series</b>	<b>1526 Series</b>	<b>1536 Series</b>	<b>4330 Series</b>
<b>Catalog Location</b>	pgs. 22-23	pgs. 24-25	pgs. 26-27	pgs. 28-29	pgs. 30-31	pgs. 32-33
<b>MS Qualified</b>	MS26574	MS3320 (AS33201)	NA	NA	NA	MS14154
<b>Description</b>	Sub-miniature, High-Performance, Lightweight	Sub-miniature, Lightweight, Ambient Temperature Compensated	Heavy Duty, High Capacity Protection	Fast-trip, Hot-wire, Ambient Temperature Compensated	Miniature, Lightweight, Ambient Temperature Compensated	Sub-miniature, Lightweight, Ambient Temperature Compensated
<b>Current Rating</b>	0.5 to 25 Amperes	1 to 25 Amperes	50 to 200 Amperes	1 to 15 Amperes	5 to 50 Amperes	1 to 25 Amperes
<b>Voltage rating (For Interrupting Capacity)</b>	120 VAC, 400 Hz; 28 VDC	120 VAC, 400 Hz; 28 VDC	120 VAC, 400 Hz	120 VAC, 400 Hz	120 VAC, 400 Hz	120 VAC, 400 Hz
<b>Calibration @25 C (percent of amperage rating)</b>	115% Hold 150% within one hour	115% Hold 138% within one hour	105% Hold 138% <sup>(1)</sup> within one hour	115% Hold 138% within one hour	105% Hold 138% <sup>(1)</sup> within one hour	110% Hold 145% within one hour
<b>Trip Time (in seconds at 25 C)</b>	All amperages	All amperages	All amperages	1-75A / 10-15A	All amperages	All amperages
<b>200% Overload</b>	2.0 to 20.0	5.0 to 20.0	15.0 to 70.0	0.35 to 4.0/3.0 to 10.0	10.0 to 70.0	4.0 to 20.0
<b>500% Overload</b>	0.16 to 1.2	0.5 to 2.0	1.2 to 6.0 <sup>(2)</sup>	0.06 to 0.45/0.4 to 0.95 <sup>(2)</sup>	1.4 to 6.0 <sup>(2)</sup>	0.40 to 2.00
<b>1000% Overload</b>	0.046 to 0.8	0.12 to 0.53	0.4 to 2.0 <sup>(3)</sup>	0.02 to 0.15/0.15 to 0.5 <sup>(3)</sup>	0.35 to 1.4 <sup>(3)</sup>	0.10 to 0.53
<b>Interrupting Capacity (Rating Dependent)</b>	500A to Unlimited @ 120V AC 2000A to Unlimited @ 28V DC	2000 to 3500A @ 120V AC 6,000A @ 28V DC	1200A @ 120V AC	300A @ 120V AC	1000A @ 120V AC	2000A @ 120V AC
<b>Weight g (lb.)</b>	22g (.048 lb)	25g (.055lb)	388g (.854 lb)	154g (.340lb)	130g (.290 lb)	68g (.150 lb)
<b>Major Dimensions LxWxH (inches)</b>	1.525 x 0.780 x 0.593	1.343 x 0.781 x 0.593	2.437 x 2.187 x 2.631	1.875 x 2.063 x 1.300	2.170 x 2.160 x 1.312	1.381 x 1.840 x 0.781
<b>Notes</b>	MIL spec approved random vibration and long button models. Available with auxiliary switch and variations in termination and mounting. 0.5 and 25 ampere rating not MIL spec approved.	MIL spec approved long button and high vibration models. Available with auxiliary switch and variations in termination and mounting. 1.5 & 25 ampere ratings not MIL spec approved.	All data listed is applicable to the 940 Series. Consult Eaton for details on the 180, 920, 930, 960, and 970 Series devices.	For additional amperage ratings consult business unit.	Single hole mount and small size facilitate easy installation.	MIL spec approved high vibration and long button models. 25 ampere rating is not MIL spec approved. Single Hole mount. Variation in termination and mounting available.



**Standard**

**Single-Pole High Performance**

**Qualified**

To MIL-C-5809 and MS25361.

**Protection For Heavy-Duty Systems**

Protects circuits from 50 to 100 amperes.

**Heavy-Duty Construction**

Breaker features large contacts and wide terminals.

**Not Sensitive To Frequency**

May be used on either AC or DC circuits.

**Performance Rated Circuit Breaker**

The 160 series has the recognition of being the most specified heavy-duty aircraft type circuit breaker in the 50 to 100 ampere rating range.

Designed to protect heavy-duty aircraft and non-aircraft electrical systems, this trip-free breaker features separate, durable, overload and mechanical latches. In addition, the overload latch is designed for precise operation. Extra heavy contacts are spring-loaded to maintain high-contact pressure and assure long life. Contact material has high resistance to arcing and the corrosive action of moisture —thus assuring low voltage drop throughout the life of the breaker.

**PERFORMANCE DATA**

<b>Interrupting Capacity</b>	6,000A at 30V, DC; 3,500A at 120V, 400 Hz., AC
<b>Endurance</b>	At 120VAC, 400 Hz.: inductive load — 5,000 cycles; resistive load — 5,000 cycles; at 30V, DC: inductive load — 2,500 cycles; resistive load — 5,000 cycles; mechanical cycling, no load — 5,000 cycles
<b>Overload Cycling</b>	100 operations at 200% rated current and rated voltage
<b>Dielectric Strength</b>	At sea level, 25°C 1,500V, AC. At 70,000 ft., 71°C 500V, AC
<b>Insulation Resistance</b>	Not less than 100 megohms at 500V, DC
<b>Voltage Drop</b>	0.15V, maximum
<b>Vibration</b>	Meets specification MIL-STD-202, Method 204, Condition A-10G, 10-500 Hz. MS "V" type series (160-086) meets Condition B 15G, 10-2,000 Hz., and Condition C 10g 10-2,000 Hz. (Random vibration also available)
<b>Shock</b>	Exceeds 30G's, 11 Millisec (half-sine pulse) MIL-STD-202, Method 213 Test J
<b>Acceleration</b>	Exceeds 10G's
<b>Weight</b>	113 grams (0.25 lbs.)

**OVERLOAD CALIBRATION DATA**

Specification Table	@ 25°C		@ +71°C		@ -40°C		Test Time Parameters
	MIN	MAX	MIN	MAX	MIN	MAX	
Must Hold	105	—	70	—	125	—	% For 1 Hour
Must Trip	—	138	—	125	—	165	% Within 1 Hour
200% Overload	15	65	—	—	—	—	Seconds
400% Overload	2	10	—	—	—	—	Seconds
600% Overload	1	4	—	—	—	—	Seconds

Trip curve available.

**ORDERING INFORMATION**

MS APPROVAL STATUS	AMPERE RATING	VOLTAGE DROP MAX. *	STANDARD		HIGH VIBRATION	
			MS P/N	EATON MP P/N	MS P/N	EATON MP P/N
MS Approved	50	0.15	MS25361-50	160-012-50	MS25361-50V	160-086-50
MS Approved	60	0.15	MS25361-60	160-012-60	MS25361-60V	160-086-60
MS Approved	70	0.15	MS25361-70	160-012-70	MS25361-70V	160-086-70
MS Approved	75	0.15	MS25361-75	160-012-75	MS25361-75V	160-086-75
MS Approved	80	0.15	MS25361-80	160-012-80	MS25361-80V	160-086-80
MS Approved	90	0.15	MS25361-90	160-012-90	MS25361-90V	160-086-90
MS Approved	100	0.15	MS25361-100	160-012-100	MS25361-100V	160-086-100

\* AT RATED NOMINAL CURRENT  
 3 Phase variants are available as a 940 Series.  
 For other amperage ratings and configurations, consult the Business Unit.

DIMENSIONS

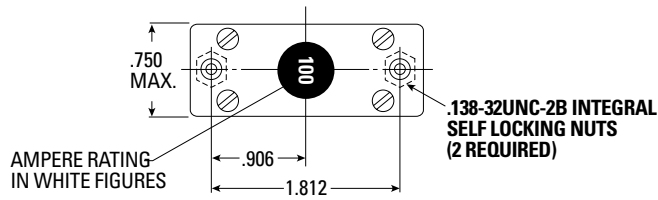

RECOMMENDED MOUNTING

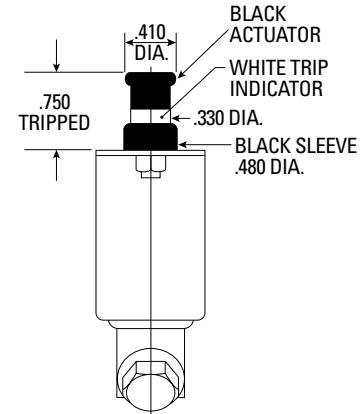
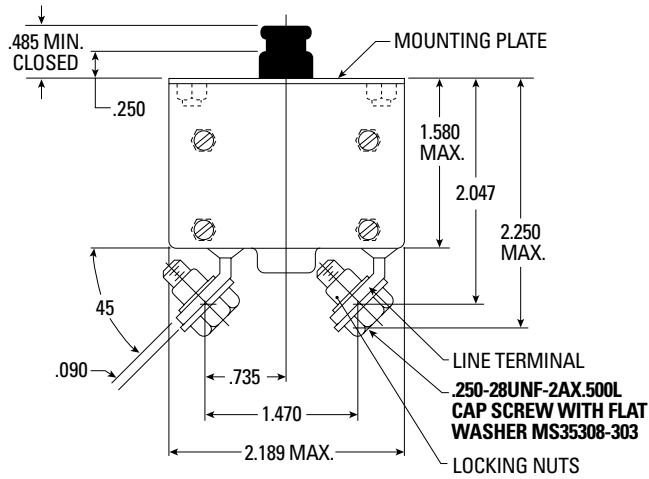
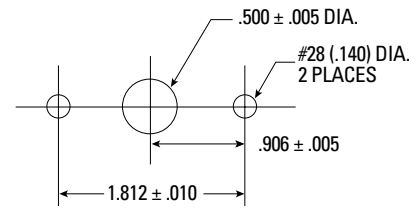

TRIP CURVE

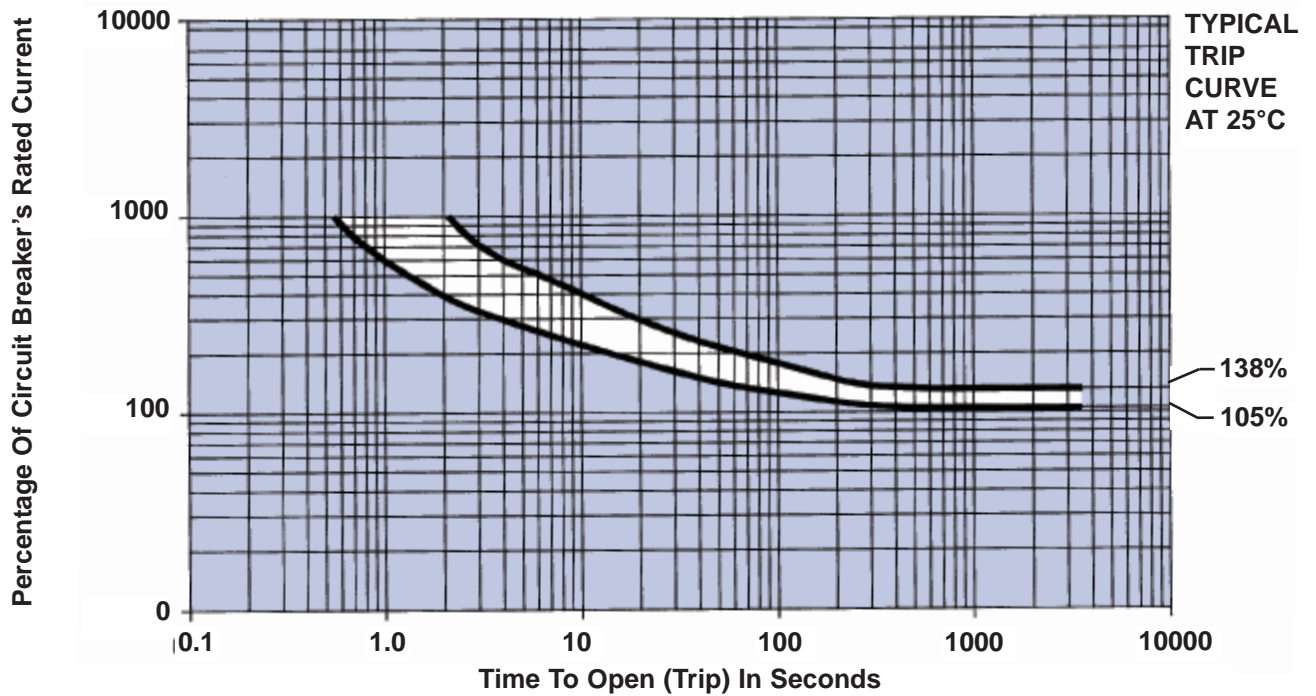



**Single-Pole High Performance**

**Protection For Very High Current Rated Circuits**

Protects circuits from 125 to 200 amperes.

**Meets MS Mounting Dimensions**

Has mounting dimensions compatible with Military Standard Drawing requirements of MS25017 of MIL-C-5809.

**Heavy-Duty Components**

Extra heavy contacts and wide sturdy terminals.

**Trouble-Free Contact Life**

Contacts mounted on spring-loaded pivots to maintain high-contact pressure and to improve arc quenching capability.

**Performance Rated Circuit Breaker**

The 170 series is the only compact, reliable, heavy-duty aircraft-type circuit breaker available in the 125 to 200 ampere range. It is the only device in this range that has mounting dimensions compatible with Military Standard Drawing MS25017. Designed to protect heavy-duty aircraft electrical systems, the breaker features separate overload and mechanical latches. The unit's trip-free design prevents it from being held closed manually against any overload that would ordinarily cause it to open. The breaker may be used on either AC or DC circuits.

**PERFORMANCE DATA**

<b>Interrupting Capacity</b>	3,000A at 28V, DC; 2,500A at 115V, AC
<b>Endurance</b>	At 120V, 400 Hz.: inductive load — 2,500 cycles; resistive load — 5,000 cycles; at 30V, DC: inductive load — 1,000 cycles; resistive load — 5,000 cycles; mechanical cycling, no load — 5,000 cycles
<b>Overload Cycling</b>	100 operations at 200% rated current and rated voltage
<b>Dielectric Strength</b>	1,500V, minimum
<b>Insulation Resistance</b>	Not less than 100 megohms at 500V, DC
<b>Voltage Drop</b>	0.1 volt maximum at rated current
<b>Vibration</b>	Exceeds MIL-STD-202, Method 204, Condition A
<b>Shock</b>	Exceeds 30G's, 11 Millisec (half-sine pulse) MIL-STD-202, Method 213 Test J
<b>Acceleration</b>	Exceeds 10G's
<b>Weight</b>	130 grams (0.286 lbs.)

**OVERLOAD CALIBRATION DATA**

Specification Table	@ 25°C		@ +71°C		@ -40°C		Test Time Parameters
	MIN	MAX	MIN	MAX	MIN	MAX	
Must Hold	100	—	70	—	110	—	% For 1 Hour
Must Trip	—	125	—	125	—	160	% Within 1 Hour
200% Overload	15	70	—	—	—	—	Seconds
400% Overload	2	12	—	—	—	—	Seconds
600% Overload	1	5	—	—	—	—	Seconds

Trip curve available.

**ORDERING INFORMATION**

Ampere Rating	Voltage Drop Max.*	Part Number
125	.100	170-001-125
140	.100	170-001-140
150	.100	170-001-150
160	.100	170-001-160
180	.100	170-001-180
200	.100	170-001-200

\* At rated nominal current.

Three phase variants are available as a 970 Series. Also available as a 180 Series device for ratings up to 300 amperes. For other amperage ratings and configurations, consult the Business Unit.

DIMENSIONS

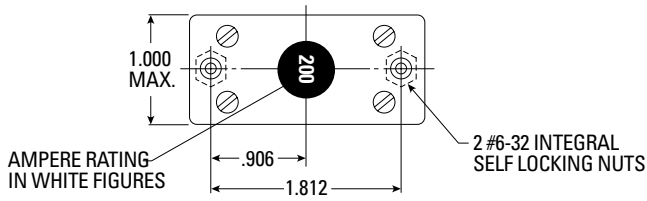

RECOMMENDED MOUNTING

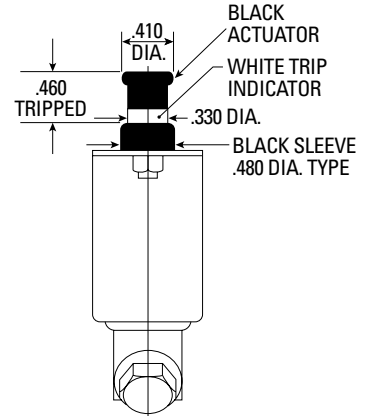
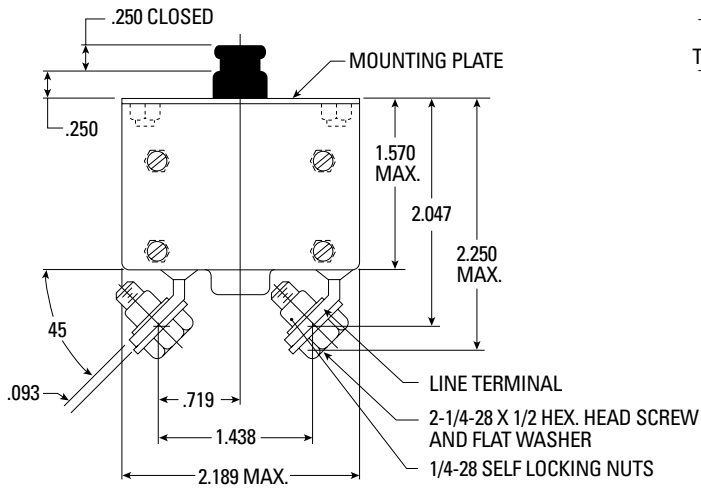
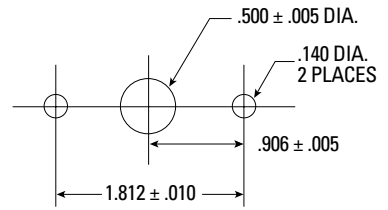

TRIP CURVE

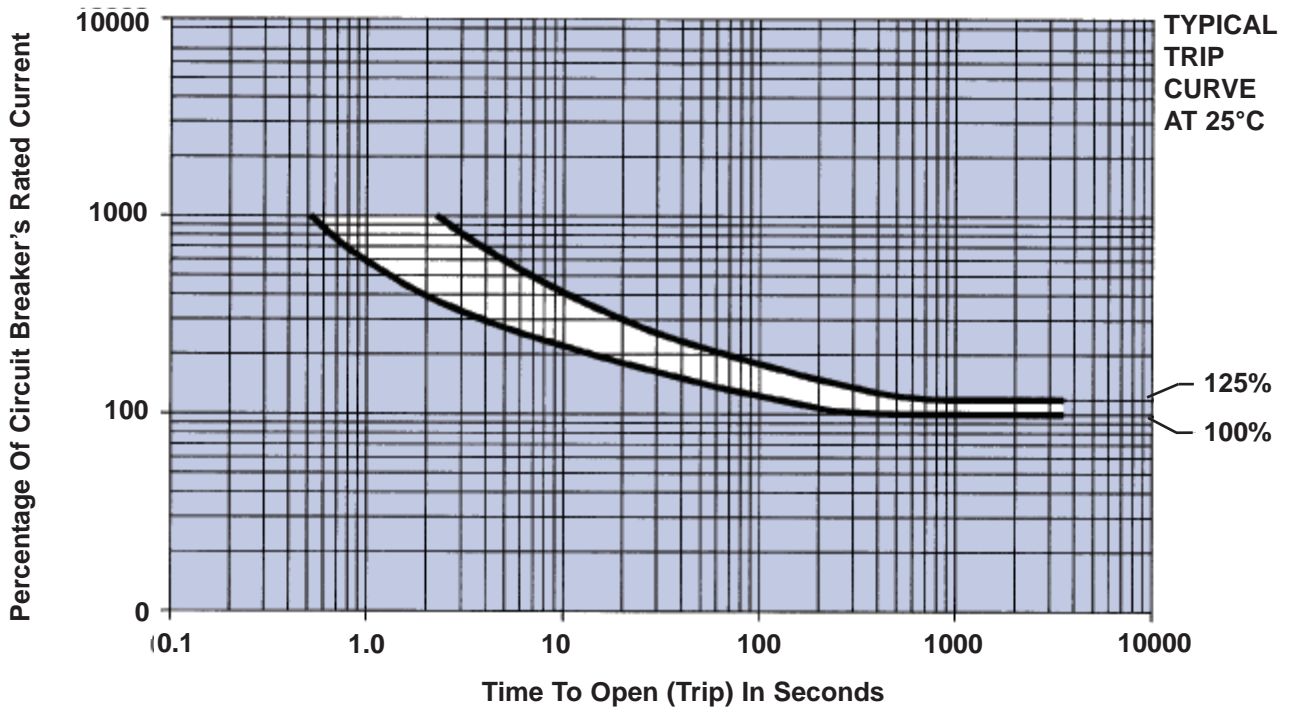



**Standard  
(Bushing  
Mounting)**



**High/Random  
Vibration (Flush  
Mounting)**

**Single-Pole High Performance**

**Qualified**

To MS25244, MS25244-P and MS25244-PT of MIL-C-5809 (MS25244PT is a substitute for MS25017) .

**Lightweight**

Circuit breaker weighs only 43 grams.

**High Interrupting Capacity**

Interrupts a 6,000A circuit at 30V, DC; 3,500A circuit at 120V, 400 Hz. AC.

**Performance Rated Circuit Breaker**

Exceeds military specification requirements for durability, vibration, mechanical shock, and acceleration. The 700 is a miniature push-pull breaker offering fast trip and high interrupting capacity. Its trip-free design prevents the breaker from being held closed manually on overloads.

A feature of the breaker is separate overload and mechanical latches. Separated in this way, the mechanical latch assures maximum endurance for the thousands of cycles of manual on-off operation, while the thermal latch combines both precise operation and durability.

**Bushing and Flush Mounting Options**

**PERFORMANCE DATA**

<b>Interrupting Capacity</b>	6,000A at 30V, DC. 3,500A at 120V, 400 Hz., AC
<b>Endurance</b>	At 120V, 400 Hz., AC or 30V, DC: inductive load — 2,500 cycles; resistive load — 5,000 cycles; mechanical cycling, no load — 5,000 cycles
<b>Overload Cycling</b>	100 operations at 200% rated current and rated voltage
<b>Dielectric Strength</b>	At sea level, 25°C 1,500V, AC. At 65,000 ft., 70°C 500V, AC. 1,500V, minimum
<b>Insulation Resistance</b>	Not less than 100 megohms at 500V, DC
<b>Voltage Drop</b>	Varies with rating (see "Ordering Information")
<b>Vibration</b>	Exceeds MIL-STD-202, Method 204, Condition A (Random Optional)
<b>Shock</b>	Exceeds 30G's, 11 Millisec (half-sine pulse) MIL-STD-202, Method 213 Test J
<b>Acceleration</b>	Exceeds 10G's
<b>Weight</b>	700-001: 43 grams (.1 lbs.). 700-089: 48 grams (.11 lbs.)
<b>Altitude Maximum</b>	65,000 ft.

**OVERLOAD CALIBRATION DATA**

Specification Table	@ 25°C		@ +71°C				@ -40°C				Test Time Parameters
	MIN	MAX	0.5 - 7 1/2A		10 - 50A		0.5 - 7 1/2A		10 - 50A		
Must Hold	115	—	60	—	70	—	156	—	148	—	% For 1 Hour
Must Trip	—	138	—	108	—	114	—	178	—	178	% Within 1 Hour
200% Overload	15	55.0	—	—	—	—	—	—	—	—	Seconds
400% Overload	2	7.0	—	—	—	—	—	—	—	—	Seconds
600% Overload	1	3.5	—	—	—	—	—	—	—	—	Seconds

Trip curve available.

**ORDERING INFORMATION**

MS APPROVAL STATUS	AMPERE RATING	VOLTAGE DROP MAX. *	STANDARD		ADAPTER FLUSH MOUNTING PLATE BASE & TERMINAL CONFIGURATION STYLE "P"		ALTERNATE BASE & TERMINAL CONFIGURATION STYLE "PT"	
			MS P/N	EATON MP P/N	MS P/N	EATON MP P/N	MS P/N	EATON MP P/N
MS Approved	5	0.25	MS25244-5	700-001-5	MS25244-P5	700-089-5	MS25244-PT5	700-092-5
MS Approved	7 1/2	0.25	MS25244-7 1/2	700-001-705	MS25244-P7 1/2	700-089-705	MS25244-PT7 1/2	700-092-705
MS Approved	10	0.25	MS25244-10	700-001-10	MS25244-P10	700-089-10	MS25244-PT10	700-092-10
MS Approved	15	0.25	MS25244-15	700-001-15	MS25244-P15	700-089-15	MS25244-PT15	700-092-15
MS Approved	20	0.25	MS25244-20	700-001-20	MS25244-P20	700-089-20	MS25244-PT20	700-092-20
MS Approved	25	0.25	MS25244-25	700-001-25	MS25244-P25	700-089-25	MS25244-PT25	700-092-25
MS Approved	30	0.25	MS25244-30	700-001-30	MS25244-P30	700-089-30	MS25244-PT30	700-092-30
MS Approved	35	0.25	MS25244-35	700-001-35	MS25244-P35	700-089-35	MS25244-PT35	700-092-35
Non MS Approved	40	0.25		700-001-40		700-089-40		700-092-40
Non MS Approved	50	0.25		700-001-50		700-089-50		700-092-50

\* AT RATED NOMINAL CURRENT  
Three phase variants are available as a 930 Series.  
For other amperage ratings and configurations, consult the Business Unit.

DIMENSIONS

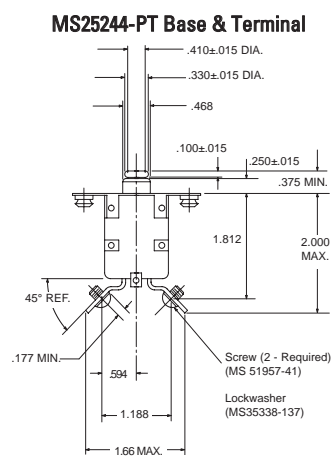
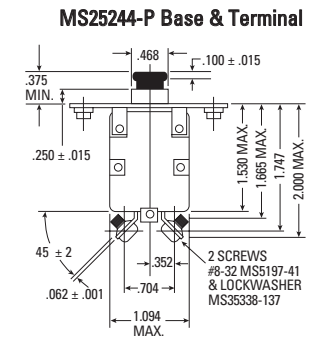
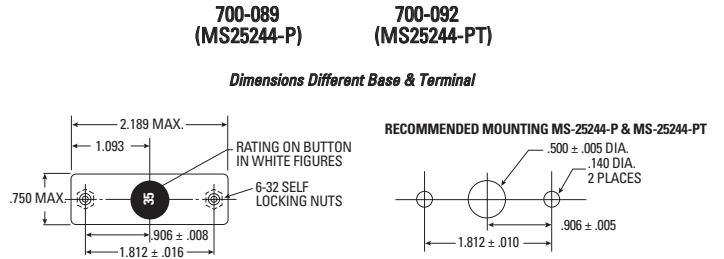
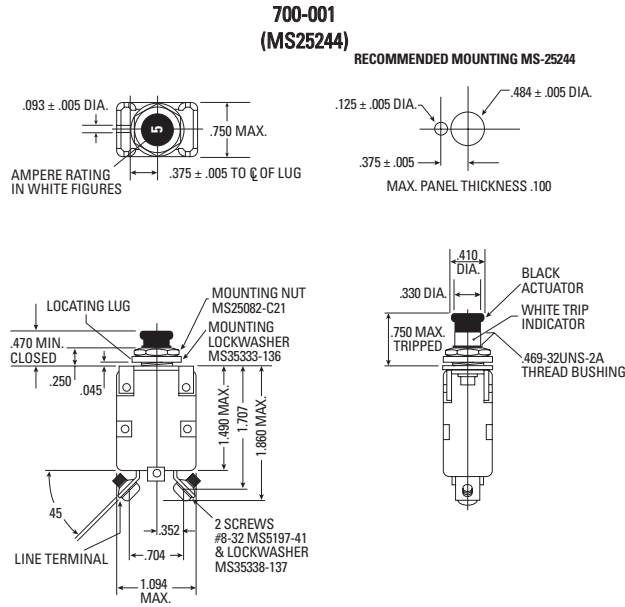

TRIP CURVE

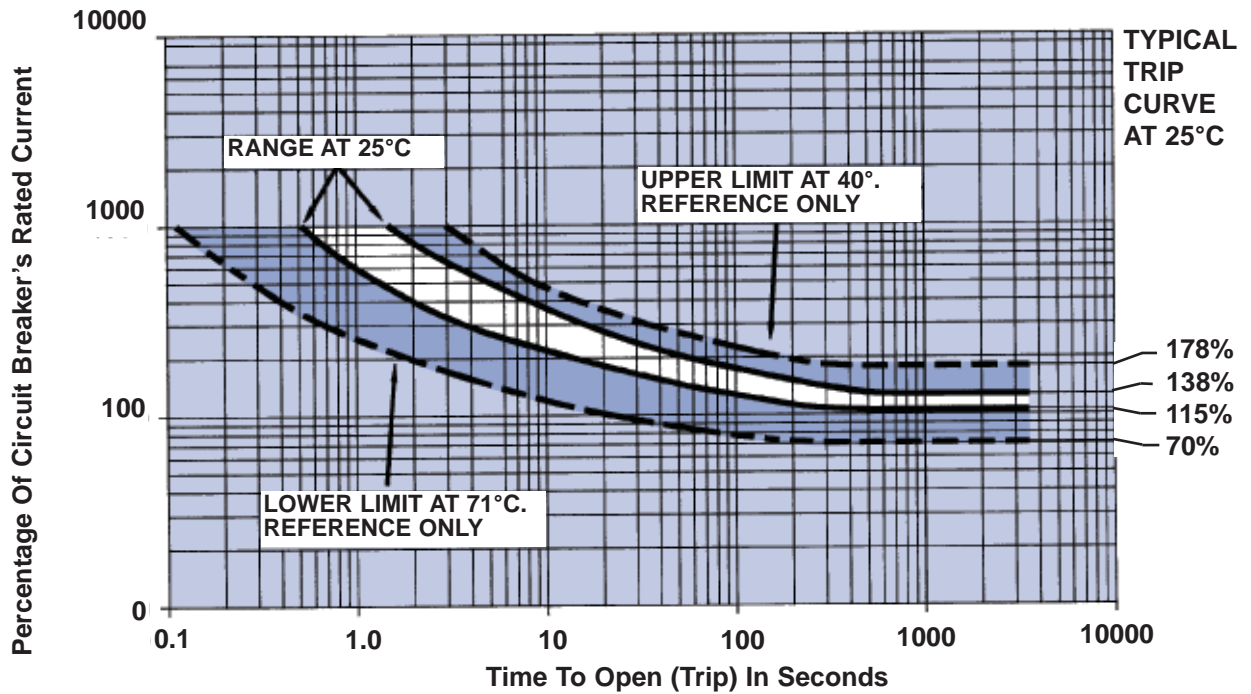



**Single-Pole High Performance**

**Qualified**

Designed to MS22074 for MIL-C-5809.

**Fast Trip**

Operates on a hot-wire principle, much faster than bimetal breakers.

**Fail-Safe Operation**

Fault cannot cause breaker to fuse closed.

**Ambient-Compensated**

No appreciable change in trip time from -40°C to +71°C.

**Low Resistance**

Silver alloy contacts maintain low resistance for life of circuit breaker.

**Load Protection**

The fast tripping circuit breaker is ideal for protecting sensitive loads such as avionics and fuel pumps where rapid detection and fault clearing are desired.

**Performance Rated Circuit Breaker**

It is the only thermal hot wire type available in ratings from one-half ampere.

The 1500 is a circuit breaker that features fast trip for quick response. Designed for the protection of both wiring and equipment, the unit provides trip indication, trip-free protection, and the convenience of manual on-off operation. Excellent temperature stability is assured by the hot-wire design. The breaker has a high resistance to shock and vibration. Its "Fail Safe" design eliminates the danger of the breaker fusing closed on overload.

**ICU Application**

This circuit breaker meets the requirements of MIL-C-83383 for use as a RCCB ICU (Indicator Control Unit). Its I2t function is per specification.

**PERFORMANCE DATA**

<b>Interrupting Capacity</b>	1/2 to 1A: 600A at 120V AC, 400 Hz.; 6,000A at 30V DC 1 1/2 to 4A: 1,000A at 120V AC 400 Hz.; 6,000A at 30V DC 5 to 10A: 600A at 120V AC 400 Hz.; 6,000A at 30V DC
<b>Endurance</b>	At 120VAC, 400 Hz., or at 30V DC; inductive load — 2,500 cycles; resistive load — 5,000 cycles; mechanical cycling, no load — 5,000 cycles
<b>Overload Cycling</b>	100 operations at 200% rated current and rated voltage
<b>Dielectric Strength</b>	1,500V, minimum
<b>Insulation Resistance</b>	Not less than 100 megohms at 500V, DC
<b>Voltage Drop</b>	Varies with rating (see "Ordering Information")
<b>Vibration</b>	Exceeds MIL-STD-202, Method 204, Condition A
<b>Shock</b>	Exceeds 30G's, 11 Millisec (half-sine pulse) MIL-STD-202, Method 213 Test J
<b>Acceleration</b>	Exceeds 10G's
<b>Weight</b>	45 grams (.099 lbs.)

**OVERLOAD CALIBRATION DATA**

Specification Table	@ 25°C				@ +71°C		@ -40°C		Test Time Parameters
	0.5 – 3A		4.5 – 10A		MIN	MAX	MIN	MAX	
	MIN	MAX	MIN	MAX					
Must Hold	115	—	115	—	115	—	115	—	% For 1 Hour
Must Trip	—	138	—	138	—	138	—	138	% Within 1 Hour
200% Overload	.400	3.0	.800	3.60	—	—	—	—	Seconds
400% Overload	.090	0.6	.140	0.75	—	—	—	—	Seconds
600% Overload	.042	0.3	.055	0.35	—	—	—	—	Seconds

Trip curve available

**ORDERING INFORMATION**

Ampere Rating	Voltage Drop Max.*	Part Number
1/2	1.21	1500-052-05
3/4	1.21	1500-052-075
1	1.20	1500-052-1
1 1/2	1.10	1500-052-105
2	0.95	1500-052-2
2 1/2	0.85	1500-052-205
3	0.81	1500-052-3
4	0.72	1500-052-4
5	0.65	1500-052-5
10	0.55	1500-052-10

\* At rated nominal current. For other amperage ratings and configurations, consult the Business Unit.

DIMENSIONS

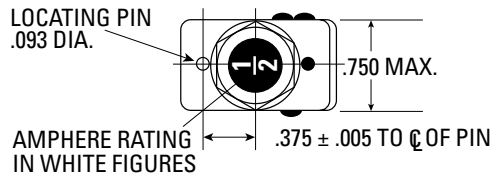

RECOMMENDED MOUNTING

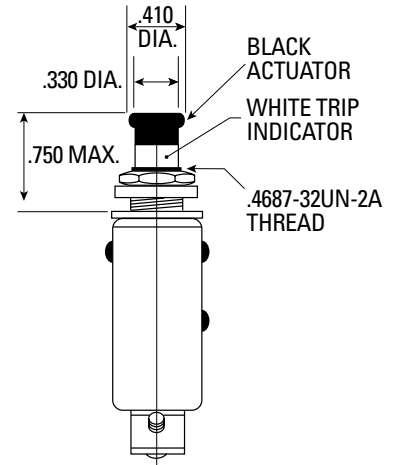
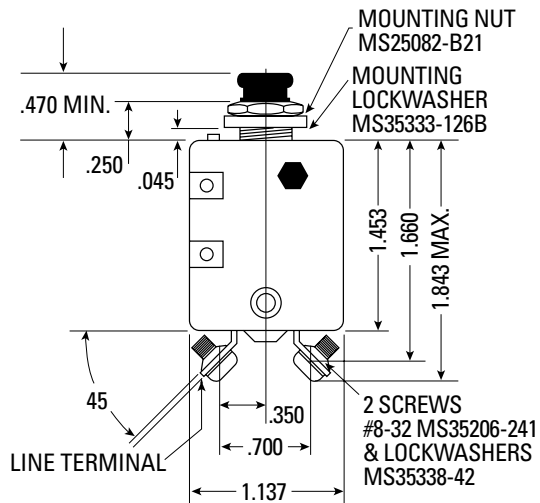
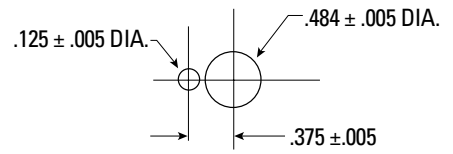

TRIP CURVE

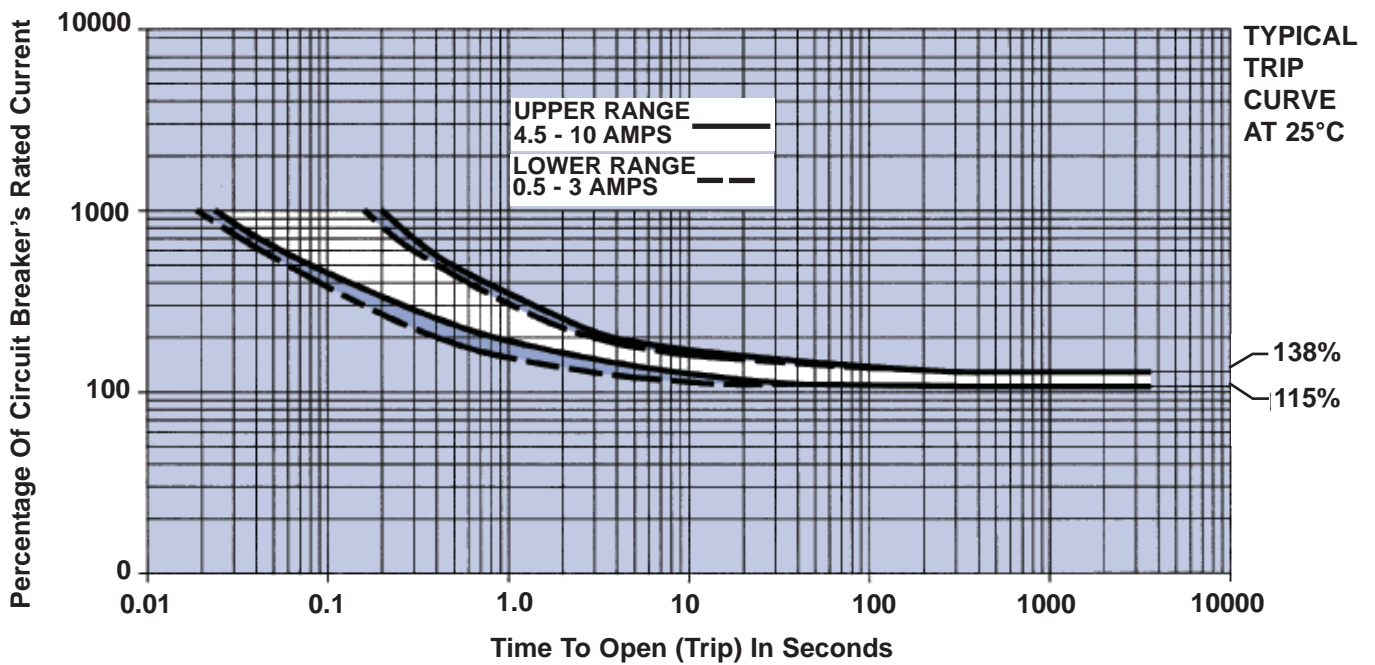



**Three-Pole High Performance**

Common trip mechanism trips all three phases, regardless of which phase is overloaded.

**Low-Current Protection**

Protects circuits in ratings from 1 to 15 amperes.

**Ambient-Compensated**

Effects of temperature on trip times are minimal.

**Fast Trip**

Operates on a hot-wire principle, much faster than bimetal breakers.

**Low Resistance**

Contacts are made from a silver alloy that maintains low resistance throughout the life of the breaker.

**Load Protection**

The fast tripping circuit breaker is ideal for protecting sensitive loads such as avionics and fuel pumps where rapid detection and fault clearing are desired.

**Performance Rated Circuit Breaker**

The 1526 Series is the only hot wire, fast-trip, three-pole circuit breaker in ratings from 1 -15 amperes. A single actuator controls all three poles, so that the breaker can be easily operated manually. There is only one overload latch; thus an overload on one pole will open all three poles simultaneously, regardless of which pole is overloaded. Long contact life is assured through the use of a low-resistance silver alloy.

**PERFORMANCE DATA**

<b>Interrupting Capacity</b>	300A at 120V, 400Hz., AC, three-phase
<b>Endurance</b>	4,000 cycles at 100% load
<b>Overload Cycling</b>	100 cycles minimum at 200% load
<b>Dielectric Strength</b>	1,500V, minimum
<b>Insulation Resistance</b>	Not less than 100 megohms at 500V, DC
<b>Voltage Drop</b>	Varies with rating (see "Ordering Information")
<b>Vibration</b>	Exceeds MIL-STD-202, Method 204, Condition A
<b>Shock</b>	Exceeds 30G's, 11 Millisec (half-sine pulse) MIL-STD-202, Method 213 Test J
<b>Acceleration</b>	Exceeds 10G's
<b>Weight</b>	154 grams (.340 lbs.)

**OVERLOAD CALIBRATION DATA**

Specification Table	@ 25°C				@ +71°C		@ -65°C		Test Time Parameters
	1- 7.5A		10 - 15A		MIN	MAX	MIN	MAX	
	MIN	MAX	MIN	MAX					
Must Hold	115	—	115	—	110	—	110	—	% For 1 Hour
Must Trip	—	138	—	138	—	138	—	138	% Within 1 Hour
200% Overload	.35	4.0	3.0	10.0	—	—	—	—	Seconds
400% Overload	.10	0.7	0.6	1.4	—	—	—	—	Seconds
600% Overload	.04	0.3	0.3	0.8	—	—	—	—	Seconds

Trip curve available.

**ORDERING INFORMATION**

Ampere Rating	Voltage Drop Max.*	Part Number
1	1.20	1526-005-1
1 1/2	1.20	1526-005-105
2	0.95	1526-005-2
2 1/2	0.85	1526-005-205
3	0.85	1526-005-3
3 1/2	0.75	1526-005-305
4	0.72	1526-005-4
5	0.65	1526-005-5
7 1/2	0.60	1526-005-705
10	0.55	1526-005-10
15	0.50	1526-005-15

\* At rated nominal current.  
For other amperage ratings and configurations, consult the Business Unit.

**DIMENSIONS**

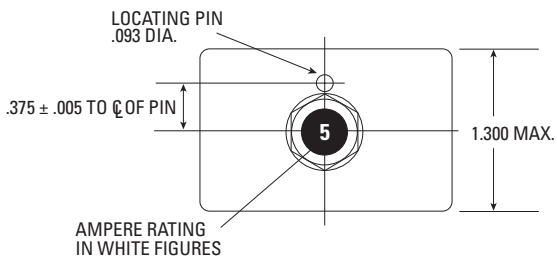

**RECOMMENDED MOUNTING**

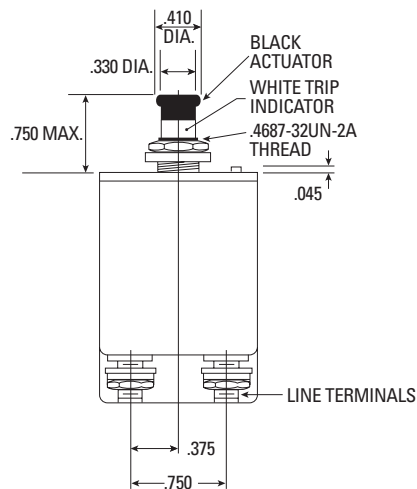
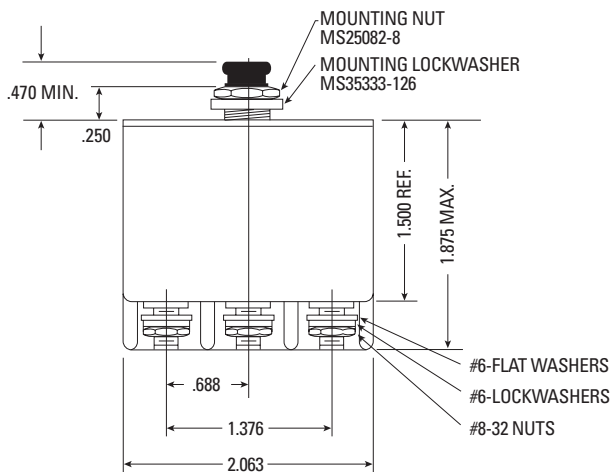
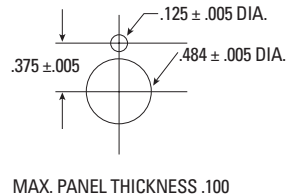

**TRIP CURVE**

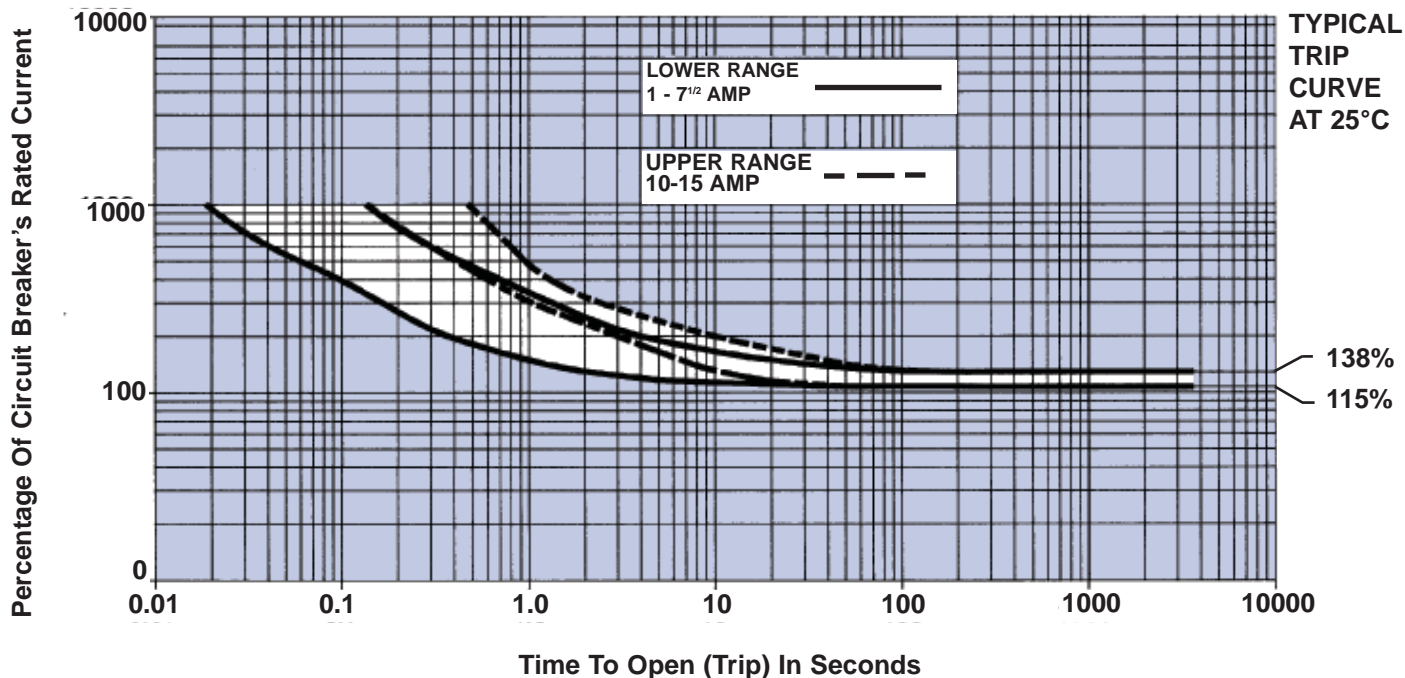



The space-qualified product utilizes the same internal design.

**Single-Pole High Performance**

**Qualified**

To MS22073 of MIL-C-5809

**Lightweight**

Under 33 grams (.073 lbs)

**High Interrupting Capacity**

Interrupts up to 6,000A circuit at 30V, DC; and up to 3,500A circuit at 120V, 400 Hz. AC.

**Not Sensitive To Frequency Or Voltage**

Breaker may be used on either AC or DC circuits.

**Performance Rated Circuit Breaker**

Meets or exceeds military specification requirements for durability, vibration, mechanical shock, and acceleration. Precision internal design provides a time-temperature characteristic capable of protecting either wire or equipment. With a case 1 1/2 inches long, the breaker weighs less than 33 grams, and is ideal for today's demanding design requirements.

**PERFORMANCE DATA**

<b>Interrupting Capacity</b>	1 to 5A: 6,000A at 30V, DC. 7 1/2 to 25A: 2,000A at 30V, DC 1A: 3,500A at 120V, 400 Hz., AC. 2 to 5A: 800A at 120V, 400 Hz., AC 7 1/2 to 25A: 500A at 120V, 400 Hz., AC
<b>Endurance*</b>	At 120V, 400 Hz., AC, or 28V, DC: inductive load — 2,500 cycles; resistive load — 5,000 cycles; mechanical cycling, no load — 5,500 cycles
<b>Overload Cycling</b>	100 operations at 200% rated current and rated voltage
<b>Dielectric Strength</b>	1,500V, minimum
<b>Insulation Resistance</b>	Not less than 100 megohms at 500V, DC
<b>Voltage Drop</b>	Varies with rating (see "Ordering Information")
<b>Vibration*</b>	Meets specification MIL-STD-202, Method 204, Condition A, 10G, 10-500 Hz. MS "V" type (4001-008) meets Condition B, 15G, 10–2,000 Hz. and Condition C, 10G, 10–2,000 Hz. MS "D" type (4001-011) meets Random Vibration Levels
<b>Shock*</b>	Exceeds 30G's, 11 Millisec (half-sine pulse) MIL-STD-202, Method 213 Test J
<b>Acceleration</b>	Exceeds 10G's
<b>Weight</b>	33 grams (0.073 lbs.)

\* Variations of these circuit breakers are capable of exceeding the standard Mil specification for endurance, vibration, and shock. Consult the business unit for more information.

**OVERLOAD CALIBRATION DATA**

Specification Table	@ 25°C		@ +71°C		@ -55°C		Test Time Parameters
	MIN	MAX	MIN	MAX	MIN	MAX	
Must Hold	115	—	90	—	135	—	% For 1 Hour
Must Trip	—	150	—	130	—	180	% Within 1 Hour
200% Overload	2.000	20.0	—	—	—	—	Seconds
500% Overload	0.160	2.0	—	—	—	—	Seconds
1000% Overload	0.046	0.5	—	—	—	—	Seconds

Trip curve available

**ORDERING INFORMATION**

MS APPROVAL STATUS	AMPERE RATING	VOLTAGE DROP MAX. *	STANDARD		HIGH VIBRATION		RANDOM VIBRATION	
			MS P/N	EATON MP P/N	MS P/N	EATON MP P/N	MS P/N	EATON MP P/N
MS Approved	1	1.10	MS22073-1	4001-001-1	MS22073-1V	4001-008-1	MS22073-D1	4001-011-1
MS Approved	1 1/2	0.75	MS22073-1 1/2	4001-001-105	MS22073-1 1/2V	4001-008-105	MS22073-D1 1/2	4001-011-105
MS Approved	2	0.75	MS22073-2	4001-001-2	MS22073-2V	4001-008-2	MS22073-D2	4001-011-2
MS Approved	2 1/2	0.70	MS22073-2 1/2	4001-001-205	MS22073-2 1/2V	4001-008-205	MS22073-D2 1/2	4001-011-205
MS Approved	3	0.55	MS22073-3	4001-001-3	MS22073-3V	4001-008-3	MS22073-D3	4001-011-3
MS Approved	4	0.45	MS22073-4	4001-001-4	MS22073-4V	4001-008-4	MS22073-D4	4001-011-4
MS Approved	5	0.35	MS22073-5	4001-001-5	MS22073-5V	4001-008-5	MS22073-D5	4001-011-5
MS Approved	7 1/2	0.30	MS22073-7 1/2	4001-001-705	MS22073-7 1/2V	4001-008-705	MS22073-D7 1/2	4001-011-705
MS Approved	10	0.28	MS22073-10	4001-001-10	MS22073-10V	4001-008-10	MS22073-D10	4001-011-10
MS Approved	15	0.25	MS22073-15	4001-001-15	MS22073-15V	4001-008-15	MS22073-D15	4001-011-15
MS Approved	20	0.25	MS22073-20	4001-001-20	MS22073-20V	4001-008-20	MS22073-D20	4001-011-20
Non MS Approved	25	0.20	MS22073-25	4001-001-25	MS22073-D25V	4001-008-25	MS22073-D25	4001-011-25

\* AT RATED NOMINAL CURRENT

For other amperage ratings and configurations, consult the Business Unit.

DIMENSIONS

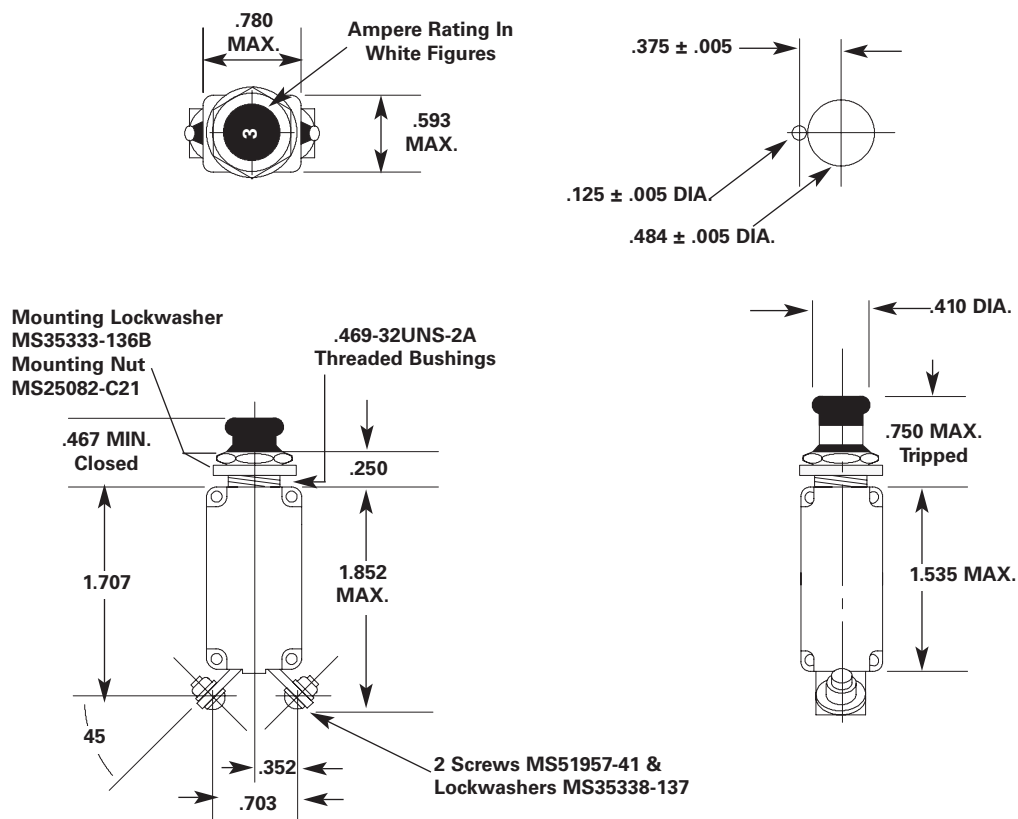

TRIP CURVE

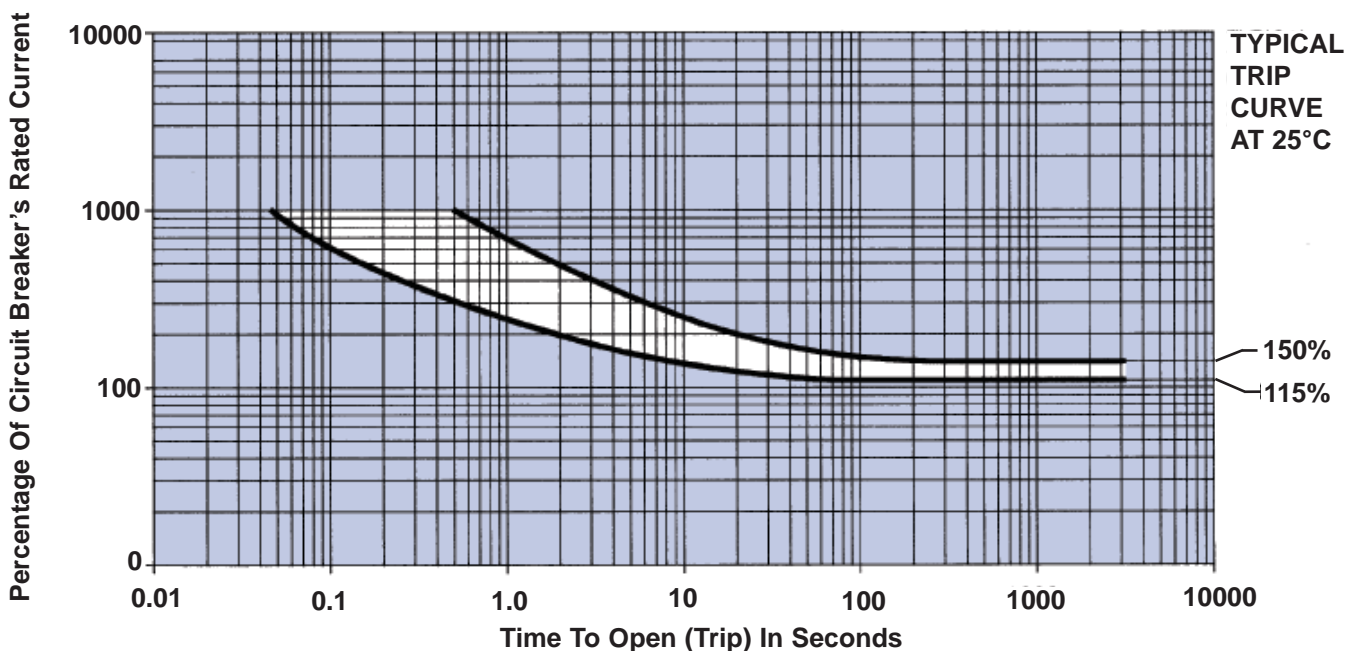



**Standard**



**Longbutton**



**Auxiliary Terminal**

The space-qualified product utilizes the same internal design.

**Single-Pole High Performance**

**Qualified**

To MS26574 of MIL-C-5809

**Lightweight**

22 grams (.048 lbs)

**High Interrupting Capacity**

**High Vibration and Shock Resistance**

**Sub-Miniature Size**

**Performance Rated Circuit Breaker**

The 4200 is a sub-miniature, lightweight, trip free, single phase circuit breaker, which combines its compact size with a proven technological track record. A modification of the popular 4310 series, its reliability has been long established.

Options such as long button, high vibration resistance, and hardware variations will enhance its versatility. The 4200 reacts consistently in extreme fluctuations of temperature, high shock, vibration, or humidity.

**Auxiliary Switch And Terminals**

The 4200 Series is also available in an Auxiliary Switch version (4200-004) to provide a remote indication of a trip condition. In a trip condition, the contacts in the auxiliary switch are in a closed position.

**PERFORMANCE DATA**

<b>Interrupting Capacity</b>	1 to 5A: unlimited at 28V DC; 7 1/2 to 25A: 2,000A at 28V DC 1 to 1 1/2A: unlimited at 120V 400 Hz., AC 2 to 5A: 800A at 120V, 400 Hz., AC 7 1/2 to 25A: 500 amps at 120V, 400 Hz., AC
<b>Endurance*</b>	At 120V, 400 Hz., AC or at 28V, DC: inductive load — 2,500 cycles; resistive load — 5,000 cycles; mechanical cycling, no load — 5,000 cycles
<b>Overload Cycling</b>	Minimum of 100 cycles at 200% rated current
<b>Dielectric Strength</b>	At sea level, 25°C 1,500V, AC. At 80,000 ft. 71°C 500V, AC
<b>Insulation Resistance</b>	Not less than 100 megohms at 500V, DC
<b>Voltage Drop</b>	Varies with rating (see "Ordering Information")
<b>Vibration*</b>	Meets specification MIL-STD-202, Method 204, Condition A 10-57 Hz. 06 in. Displacement Double Amplitude, and 57-500 Hz. at 10G's (Random vibration level also available)
<b>Shock*</b>	Exceeds 50G's, 11 Millisec (half-sine pulse) MIL-STD-202, Method 213A Test A
<b>Acceleration</b>	Exceeds 10G's
<b>Weight</b>	22 grams (0.048 lbs.)

\* Variations of these circuit breakers are capable of exceeding the standard Mil specification for endurance, vibration, and shock. Consult the business unit for more information.

**OVERLOAD CALIBRATION DATA**

Specification Table	@ 25°C		@ +71°C		@ -55°C		Test Time Parameters
	MIN	MAX	MIN	MAX	MIN	MAX	
Must Hold	115	—	90	—	135	—	% For 1 Hour
Must Trip	—	150	—	130	—	180	% Within 1 Hour
200% Overload	2.000	20.0	—	—	—	—	Seconds
500% Overload	0.160	1.2	—	—	—	—	Seconds
1000% Overload	0.046	0.8	—	—	—	—	Seconds

Trip curve available.

**ORDERING INFORMATION**

MS APPROVAL STATUS	AMPERE RATING	VOLTAGE DROP MAX.*	STANDARD		LONG BUTTON		RANDOM VIBRATION		AUXILIARY TERMINAL		LONG BUTTON RANDOM VIB.	
			MS P/N	EATON MP P/N	MS P/N	EATON MP P/N	MSP/N	EATON MP P/N	MS P/N	EATON MP P/N	MS P/N	EATON MP P/N
MS Approved	3/4	1.45	MS26574-3/4	4200-001-075	MS26574-3/4L	4200-003-075	MS26574-D3/4	4200-006-075	MS26574-3/4A	4200-004-075	MS26574-D3/4L	4200-007-075
MS Approved	1	1.10	MS26574-1	4200-001-1	MS26574-1L	4200-003-1	MS26574-D1	4200-006-1	MS26574-1A	4200-004-1	MS26574-D1L	4200-007-1
MS Approved	1 1/2	0.75	MS26574-1 1/2	4200-001-105	MS26574-1 1/2L	4200-003-105	MS26574-D1 1/2	4200-006-105	MS26574-1 1/2A	4200-004-105	MS26574-D1 1/2L	4200-007-105
MS Approved	2	0.75	MS26574-2	4200-001-2	MS26574-2L	4200-003-2	MS26574-D2	4200-006-2	MS26574-2A	4200-004-2	MS26574-D2L	4200-007-2
MS Approved	2 1/2	0.70	MS26574-2 1/2	4200-001-205	MS26574-2 1/2L	4200-003-205	MS26574-D2 1/2	4200-006-205	MS26574-2 1/2A	4200-004-205	MS26574-D2 1/2L	4200-007-205
MS Approved	3	0.55	MS26574-3	4200-001-3	MS26574-3L	4200-003-3	MS26574-D3	4200-006-3	MS26574-3A	4200-004-3	MS26574-D3L	4200-007-3
MS Approved	4	0.45	MS26574-4	4200-001-4	MS26574-4L	4200-003-4	MS26574-D4	4200-006-4	MS26574-4A	4200-004-4	MS26574-D4L	4200-007-4
MS Approved	5	0.35	MS26574-5	4200-001-5	MS26574-5L	4200-003-5	MS26574-D5	4200-006-5	MS26574-5A	4200-004-5	MS26574-D5L	4200-007-5
MS Approved	7 1/2	0.30	MS26574-7 1/2	4200-001-705	MS26574-7 1/2L	4200-003-705	MS26574-D7 1/2	4200-006-705	MS26574-7 1/2A	4200-004-705	MS26574-D7 1/2L	4200-007-705
MS Approved	10	0.28	MS26574-10	4200-001-10	MS26574-10L	4200-003-10	MS26574-D10	4200-006-10	MS26574-10A	4200-004-10	MS26574-D10L	4200-007-10
MS Approved	15	0.25	MS26574-15	4200-001-15	MS26574-15L	4200-003-15	MS26574-D15	4200-006-15	MS26574-15A	4200-004-15	MS26574-D15L	4200-007-15
MS Approved	20	0.25	MS26574-20	4200-001-20	MS26574-20L	4200-003-20	MS26574-D20	4200-006-20	MS26574-20A	4200-004-20	MS26574-D20L	4200-007-20
Non MS Approved	25	0.20		4200-001-25		4200-003-25		4200-006-25		4200-004-25		4200-007-25

\* AT RATED NOMINAL CURRENT  
For other amperage ratings and configurations, consult the Business Unit.

**DIMENSIONS**

Part No.	A*Max.	B*Min.
4200-001	0.759	0.407
4200-003	1.134	0.782
4200-004	0.759	0.407
4200-006	0.759	0.407
4200-007	1.0134	0.782

Min. Panel Thickness .025  
 Max. Panel Thickness .100

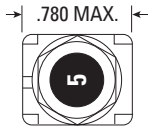

**RECOMMENDED MOUNTING**

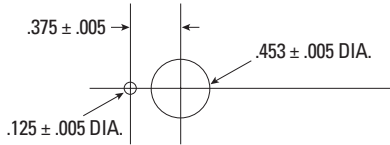

**AUXILIARY SWITCH OPERATION**

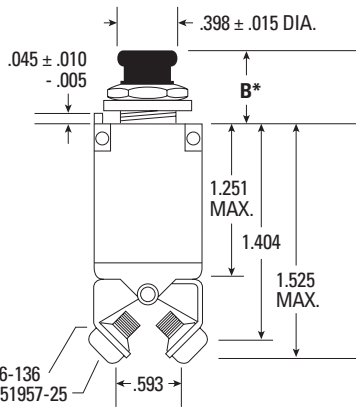
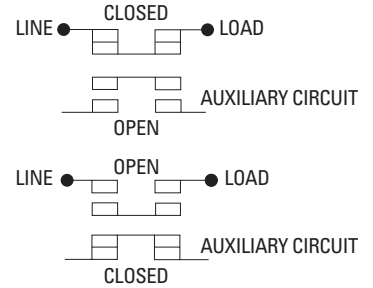

LOCKWASHER MS36336-136  
 TERMINAL SCREW MS51957-25

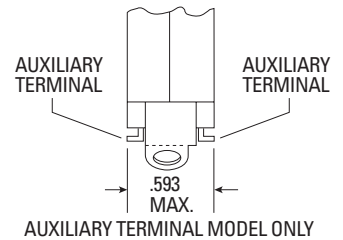
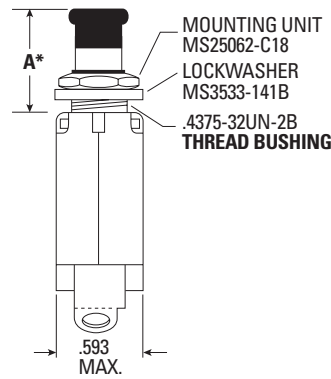

AUXILIARY TERMINAL MODEL ONLY

**TRIP CURVE**

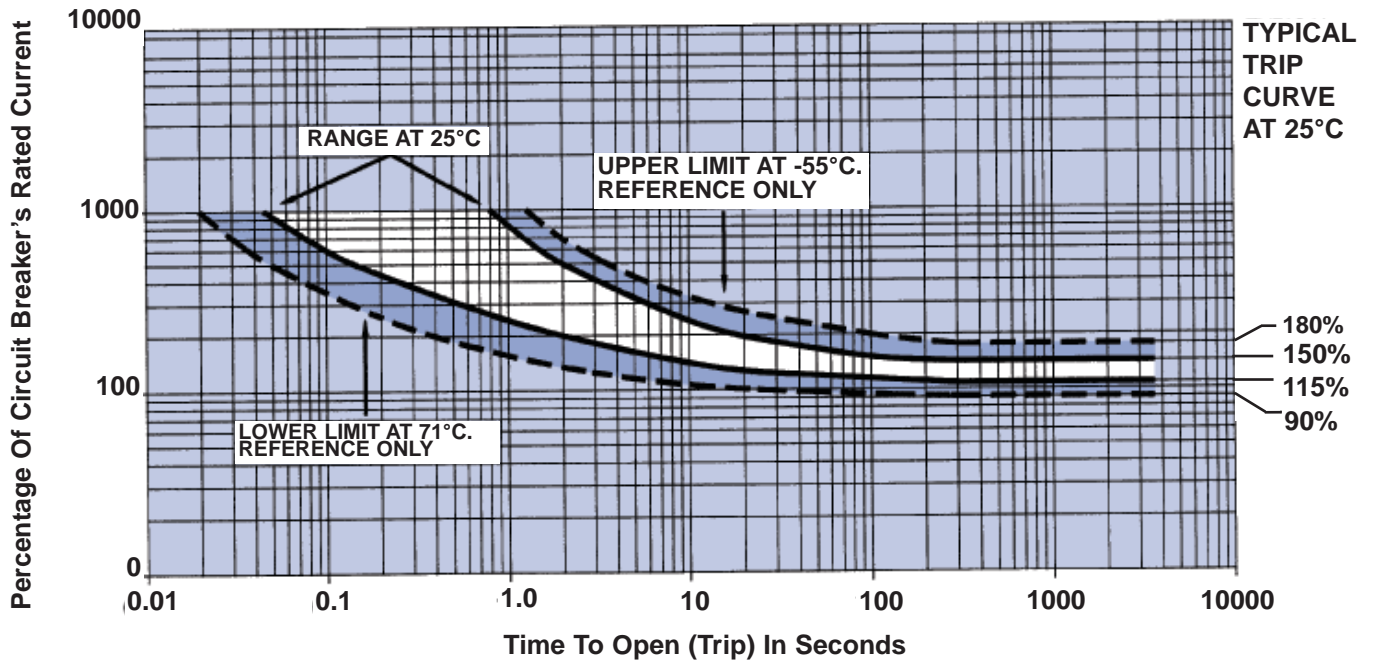



Standard

The space-qualified product utilizes the same internal design.

**Sub-Miniature Size — High Performance**

**Qualified**

To MS3320 of Mil-C-5809. Meets performance specification of MS14105 of MIL-C-5809

**High Interrupting Capacity**

Interrupts 6,000A fault at 28V, DC; up to 3,500A fault at 120V, 400 Hz., AC (ampere rating dependent).

**Vibration Resistance**

Vibration resistance and mechanical life exceed MIL Specs — including random vibration.

**Temperature-Compensated**

Ambient-temperature-compensated from -55°C to +121°C.

**Performance Rated Circuit Breaker**

The lightweight, single-phase circuit breaker, Series 4310, allows high density packaging for all aircraft and aerospace needs.

The 4310 series reflects the latest advancements in circuit breaker design — plus other proven features (e.g., self-wiping contacts).

Tight tolerances in design and stringent manufacturing standards are key factors in the reliable operation of the 4310 under severe environmental conditions of high temperature, high humidity, extreme vibration, and shock. It is also fungus- and corrosion-proof.

Calibration integrity is maintained through wide variations in ambient temperature and altitude, making this circuit breaker ideal for applications where temperature is not controlled.

**Multiple Options**

This series is available in many optional configurations.

It is presently being manufactured with 7/16, 15/32 and metric mounting sleeves. Many versions of different terminals, barriers, and hardware are current production items. Several different actuator options provide our customers with additional flexibility.

**PERFORMANCE DATA**

<b>Interrupting Capacity*</b>	1 to 25A: 6,000A at 28V, DC. 1A: 3,500A at 120V, 400 Hz., AC 1 1/2 to 2 1/2A: 2,800A at 120V, 400 Hz., AC; 3 TO 15: 2,500A AT 120V, 400 Hz., AC; 20 to 25A: 2,000A at 120V, 400 Hz., AC
<b>Endurance*</b>	At 120V, 400 Hz., AC or at 28V, DC: inductive load — 2,500 cycles; resistive load — 5,000 cycles; mechanical cycling, no load — 10,000 cycles
<b>Overload Cycling</b>	Minimum of 100 cycles at 200% rated current
<b>Dielectric Strength</b>	At sea level, 25°C 1,500V, AC. At 70,000 ft. 121°C 500V, AC
<b>Insulation Resistance</b>	Not less than 100 megohms at 500V, DC
<b>Voltage Drop</b>	Varies with rating (see "Ordering Information")
<b>Vibration*</b>	Meets specification MIL-STD-202, Method 204, Condition A-10G, 10-500 Hz. MS "V" type,(4310-019) meets Condition B, 15G, 10-2,000 Hz. and Condition C 10G, 10-2,000 Hz.
<b>Shock*</b>	Exceeds 50G's, 11 Milli-sec (half-sine pulse) MIL-STD-202, Method 213 Test A
<b>Acceleration</b>	Exceeds 10G's
<b>Weight</b>	25 grams (.055 lbs.)

\* Variations of these circuit breakers are capable of exceeding the standard Mil specification for endurance vibration, shock, and interrupting capacity. Consult the Business Unit for more information.

**OVERLOAD CALIBRATION DATA**

Specification Table	@ 25°C		@ +121°C		@ -55°C		Test Time Parameters
	MIN	MAX	MIN	MAX	MIN	MAX	
Must Hold	115	—	100	—	115	—	% For 1 Hour
Must Trip	—	138	—	138	—	160	% Within 1 Hour
200% Overload	5.00	20.00	1.500	13.00	7.00	40.00	Seconds
500% Overload	0.50	2.00	0.150	1.10	0.50	3.00	Seconds
1000% Overload	0.12	0.53	0.035	0.30	0.16	0.80	Seconds

Trip curves available.

**ORDERING INFORMATION**

MS Approval Status	AMPERE RATING	VOLTAGE DROP MAX.*	STANDARD		LONG BUTTON		HIGH VIBRATION		LONG BUTTON VIBRATION	
			MS P/N	EATON MP P/N	MS P/N	EATON MP P/N	MSP/N	EATON MP P/N	MS P/N	EATON MP P/N
MS Approved	1	1.10	MS3320-1	4310-001-1	MS3320-1L	4310-005-1	MS3320-1V	4310-019-1	MS3320-1VL	4310-024-1
Non MS Approved	1 <sup>2</sup>	0.80		4310-001-105		4310-005-105		4310-019-105		4310-024-105
MS Approved	2	0.75	MS3320-2	4310-001-2	MS3320-2L	4310-005-2	MS3320-2V	4310-019-2	MS3320-2VL	4310-024-2
MS Approved	2 <sup>2</sup>	0.70	MS3320-2 1/2	4310-001-205	MS3320-2 1/2L	4310-005-205	MS3320-2 1/2V	4310-019-205	MS3320-2 1/2VL	4310-024-205
MS Approved	3	0.55	MS3320-3	4310-001-3	MS3320-3L	4310-005-3	MS3320-3V	4310-019-3	MS3320-3VL	4310-024-3
MS Approved	4	0.45	MS3320-4	4310-001-4	MS3320-4L	4310-005-4	MS3320-4V	4310-019-4	MS3320-4VL	4310-024-4
MS Approved	5	0.35	MS3320-5	4310-001-5	MS3320-5L	4310-005-5	MS3320-5V	4310-019-5	MS3320-5VL	4310-024-5
MS Approved	7 <sup>2</sup>	0.30	MS3320-7 1/2	4310-001-705	MS3320-7 1/2L	4310-005-705	MS3320-7 1/2V	4310-019-705	MS3320-7 1/2VL	4310-024-705
MS Approved	10	0.28	MS3320-10	4310-001-10	MS3320-10L	4310-005-10	MS3320-10V	4310-019-10	MS3320-10VL	4310-024-10
MS Approved	15	0.25	MS3320-15	4310-001-15	MS3320-15L	4310-005-15	MS3320-15V	4310-019-15	MS3320-15VL	4310-024-15
MS Approved	20	0.25	MS3320-20	4310-001-20	MS3320-20L	4310-005-20	MS3320-20V	4310-019-20	MS3320-20VL	4310-024-20
Non MS Approved	25	0.20		4310-001-25		4310-005-25		4310-019-25		4310-024-25

\* AT RATED NOMINAL CURRENT  
An auxiliary terminal version of the circuit breaker is available as 4380 Series.  
For other amperage ratings and configurations, consult the Business Unit.

DIMENSIONS

MIL Spec	Part No.	A*Max.	B*Min.
MS3320	4310-001	0.750	0.470
MS3320L	4310-005	1.125	0.845
MS3320V	4310-019	0.750	0.470
MS3320VL	4310-024	1.125	0.845

Min. Panel Thickness .025  
 Max. Panel Thickness .100

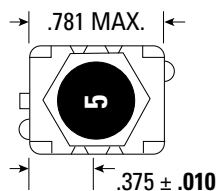

RECOMMENDED MOUNTING

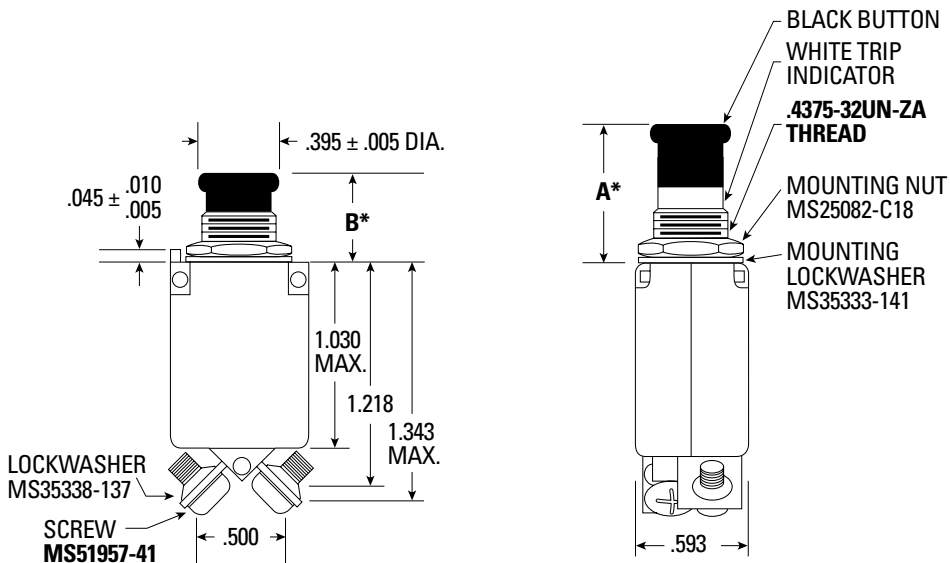
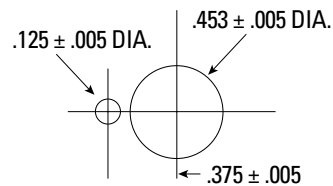

TRIP CURVE

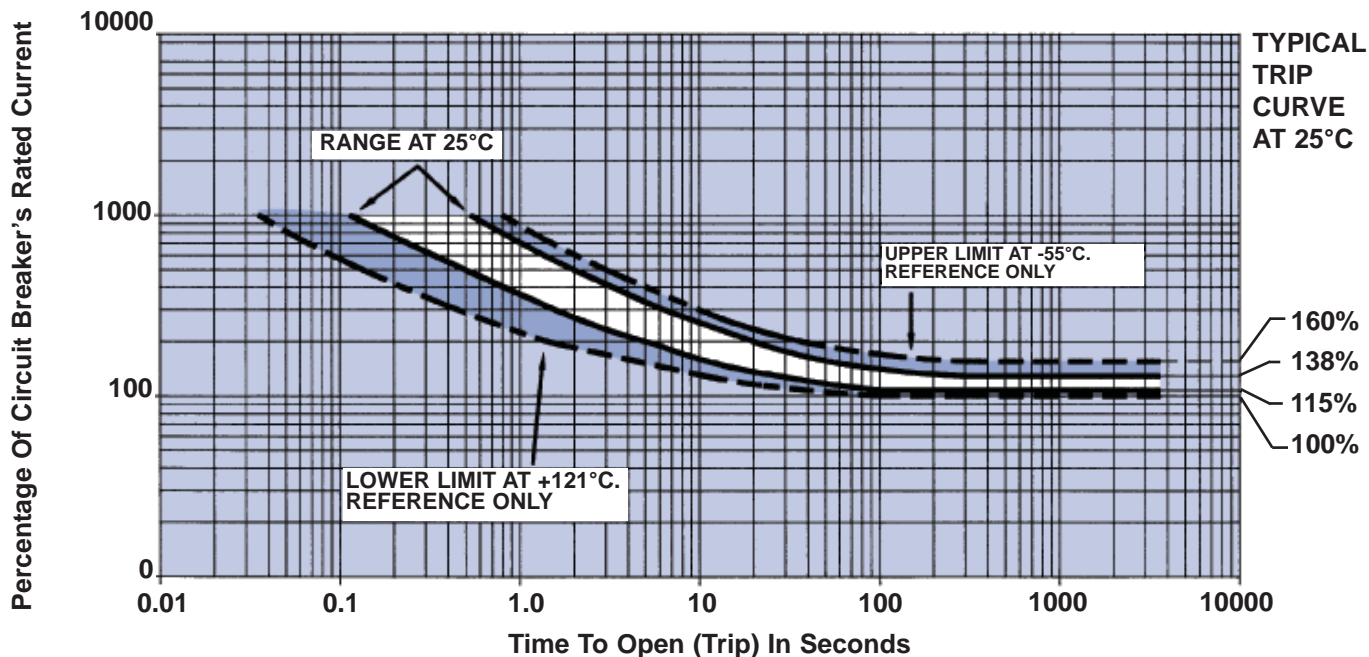



**Heavy-Duty Three-Pole High Performance**

Three-phase protection of circuits from 50 to 100 amperes.

**Interphase Insulation**

Insulating interphase barriers separate adjacent terminals.

**Common Trip Bar**

One bar connects the three operating mechanisms for simultaneous trip action. Trip bar is removable for installation.

**Performance Rated Circuit Breaker**

The 940 series is the only three-pole heavy-duty aircraft-type circuit breaker available in the 50 to 100 ampere range and consists of three specially built 160-012 breakers with insulating interphase barriers separating adjacent terminals. The unit has a common trip bar connecting the three operating mechanisms so that an overload tripping one pole will simultaneously trip the remaining two poles.

**PERFORMANCE DATA**

<b>Interrupting Capacity</b>	1,200A at 120V 400 Hz., AC
<b>Endurance</b>	At 120VAC, 400 Hz.: inductive load — 5,000 cycles; resistive load — 5,000 cycles; mechanical cycling, no load — 5,000 cycles
<b>Overload Cycling</b>	100 cycles minimum at 200% rated current and rated voltage
<b>Dielectric Strength</b>	1,500V, minimum
<b>Insulation Resistance</b>	Not less than 100 megohms at 500V, DC
<b>Voltage Drop</b>	Varies with rating (see "Ordering Information")
<b>Vibration</b>	Exceeds MIL-STD-202, Method 204, Condition A except, 7G peak
<b>Shock</b>	Exceeds 30G's, 11 Millisec (half-sine pulse) MIL-STD-202, Method 213 Test J
<b>Acceleration</b>	Exceeds 10G's
<b>Weight</b>	390 grams (.860 lbs.)

**OVERLOAD CALIBRATION DATA**

Specification Table	@ 25°C		@ +71°C		@ -40°C		Test Time Parameters
	MIN	MAX	MIN	MAX	MIN	MAX	
Must Hold	105	—	70	—	145	—	% For 1 Hour
Must Trip	—	138	—	115	—	170	% Within 1 Hour
200% Overload	15	70	—	—	—	—	Seconds
400% Overload	2	10	—	—	—	—	Seconds
600% Overload	1	4	—	—	—	—	Seconds

Trip curve available.

**ORDERING INFORMATION**

Ampere Rating	Voltage Drop Max.*	Part Number
50	0.15	940-006-50
60	0.15	940-006-60
70	0.15	940-006-70
75	0.15	940-006-75
80	0.15	940-006-80
90	0.15	940-006-90
100	0.15	940-006-100

\* At rated nominal current.

Data depicted is for the 940 Series. Also available to order are 920, 930, 960, and 970 Series devices. For other amperage ratings and configurations, consult the Business Unit.

DIMENSIONS

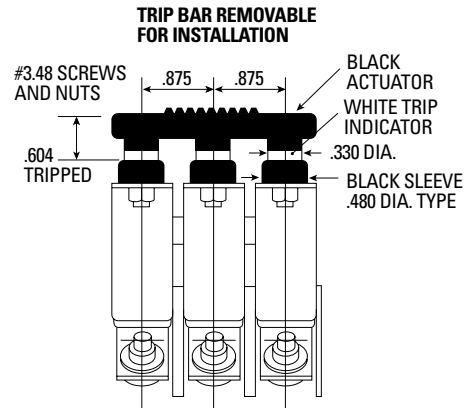
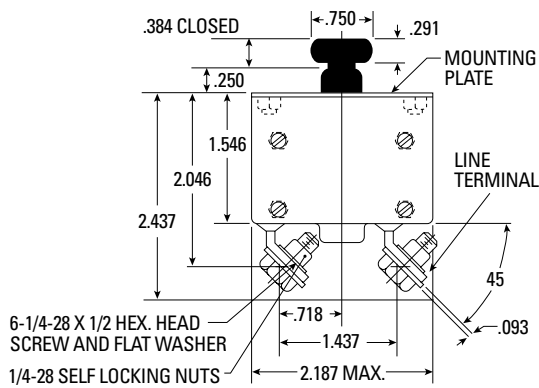
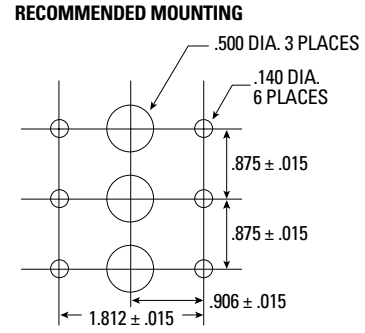
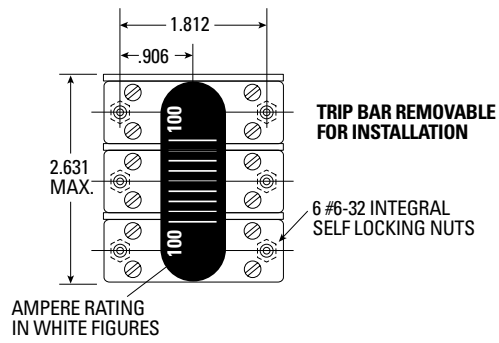

TRIP CURVE

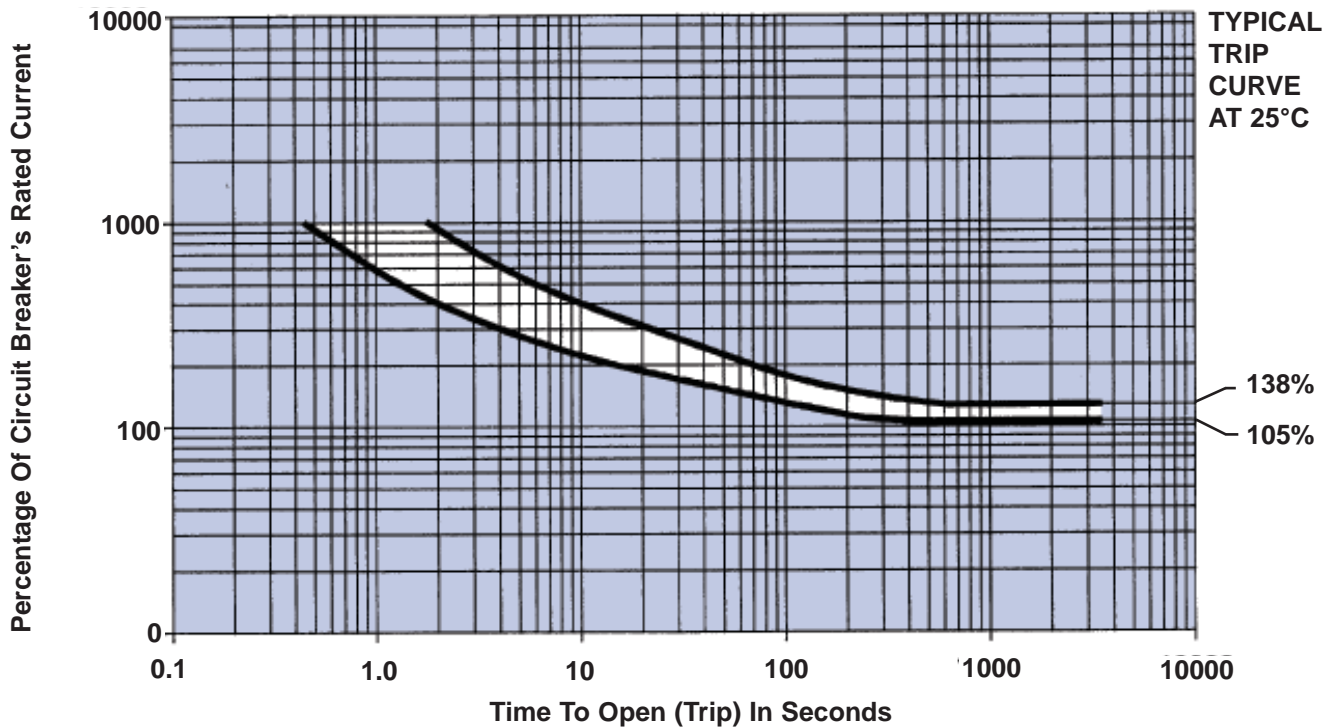



**Three-Pole High Performance**

Common trip mechanism trips all three phases, regardless of which phase is overloaded.

**Low-Current Protection**

Protects circuits in ratings from 1 to 15 amperes.

**Ambient-Compensated**

Effects of temperature on trip times are minimal.

**Fast Trip**

Operates on a hot-wire principle, much faster than bimetal breakers.

**Low Resistance**

Contacts are made from a silver alloy that maintains low resistance throughout the life of the breaker.

**Load Protection**

The fast tripping circuit breaker is ideal for protecting sensitive loads such as avionics and fuel pumps where rapid detection and fault clearing are desired.

**Performance Rated Circuit Breaker**

The 1526 Series is the only hot wire, fast-trip, three-pole circuit breaker in ratings from 1 -15 amperes. A single actuator controls all three poles, so that the breaker can be easily operated manually. There is only one overload latch; thus an overload on one pole will open all three poles simultaneously, regardless of which pole is overloaded. Long contact life is assured through the use of a low-resistance silver alloy.

**PERFORMANCE DATA**

<b>Interrupting Capacity</b>	300A at 120V, 400Hz., AC, three-phase
<b>Endurance</b>	4,000 cycles at 100% load
<b>Overload Cycling</b>	100 cycles minimum at 200% load
<b>Dielectric Strength</b>	1,500V, minimum
<b>Insulation Resistance</b>	Not less than 100 megohms at 500V, DC
<b>Voltage Drop</b>	Varies with rating (see "Ordering Information")
<b>Vibration</b>	Exceeds MIL-STD-202, Method 204, Condition A
<b>Shock</b>	Exceeds 30G's, 11 Millisec (half-sine pulse) MIL-STD-202, Method 213 Test J
<b>Acceleration</b>	Exceeds 10G's
<b>Weight</b>	154 grams (.340 lbs.)

**OVERLOAD CALIBRATION DATA**

Specification Table	@ 25°C				@ +71°C		@ -65°C		Test Time Parameters
	1- 7.5A		10 - 15A		MIN	MAX	MIN	MAX	
	MIN	MAX	MIN	MAX					
Must Hold	115	—	115	—	110	—	110	—	% For 1 Hour
Must Trip	—	138	—	138	—	138	—	138	% Within 1 Hour
200% Overload	.35	4.0	3.0	10.0	—	—	—	—	Seconds
400% Overload	.10	0.7	0.6	1.4	—	—	—	—	Seconds
600% Overload	.04	0.3	0.3	0.8	—	—	—	—	Seconds

Trip curve available.

**ORDERING INFORMATION**

Ampere Rating	Voltage Drop Max.*	Part Number
1	1.20	1526-005-1
1 1/2	1.20	1526-005-105
2	0.95	1526-005-2
2 1/2	0.85	1526-005-205
3	0.85	1526-005-3
3 1/2	0.75	1526-005-305
4	0.72	1526-005-4
5	0.65	1526-005-5
7 1/2	0.60	1526-005-705
10	0.55	1526-005-10
15	0.50	1526-005-15

\* At rated nominal current.  
For other amperage ratings and configurations, consult the Business Unit.

DIMENSIONS

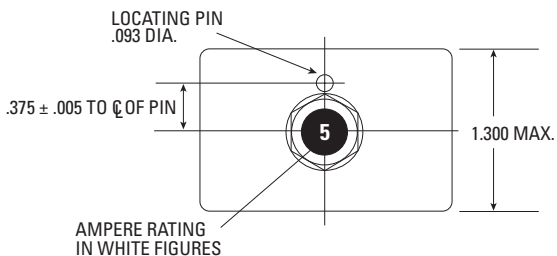

RECOMMENDED MOUNTING

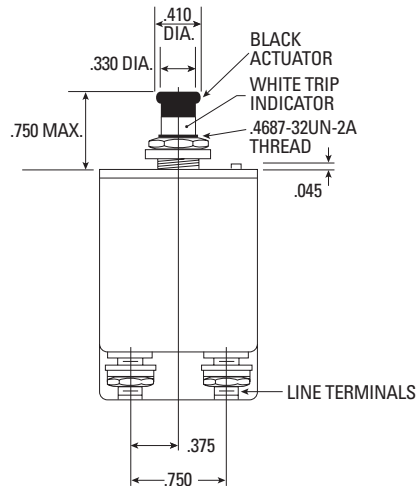
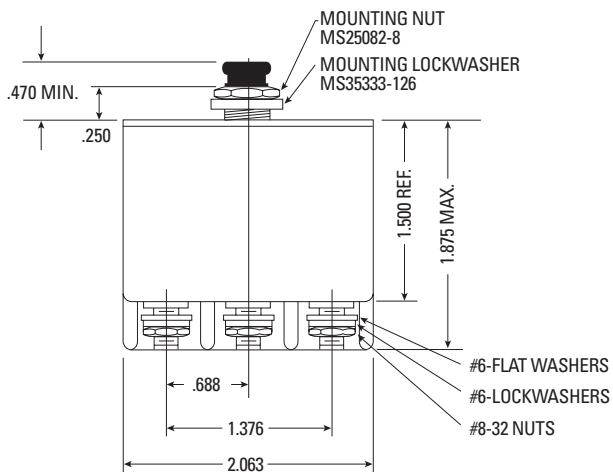
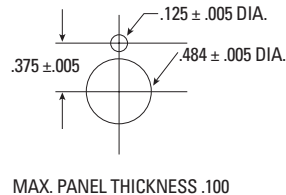

TRIP CURVE

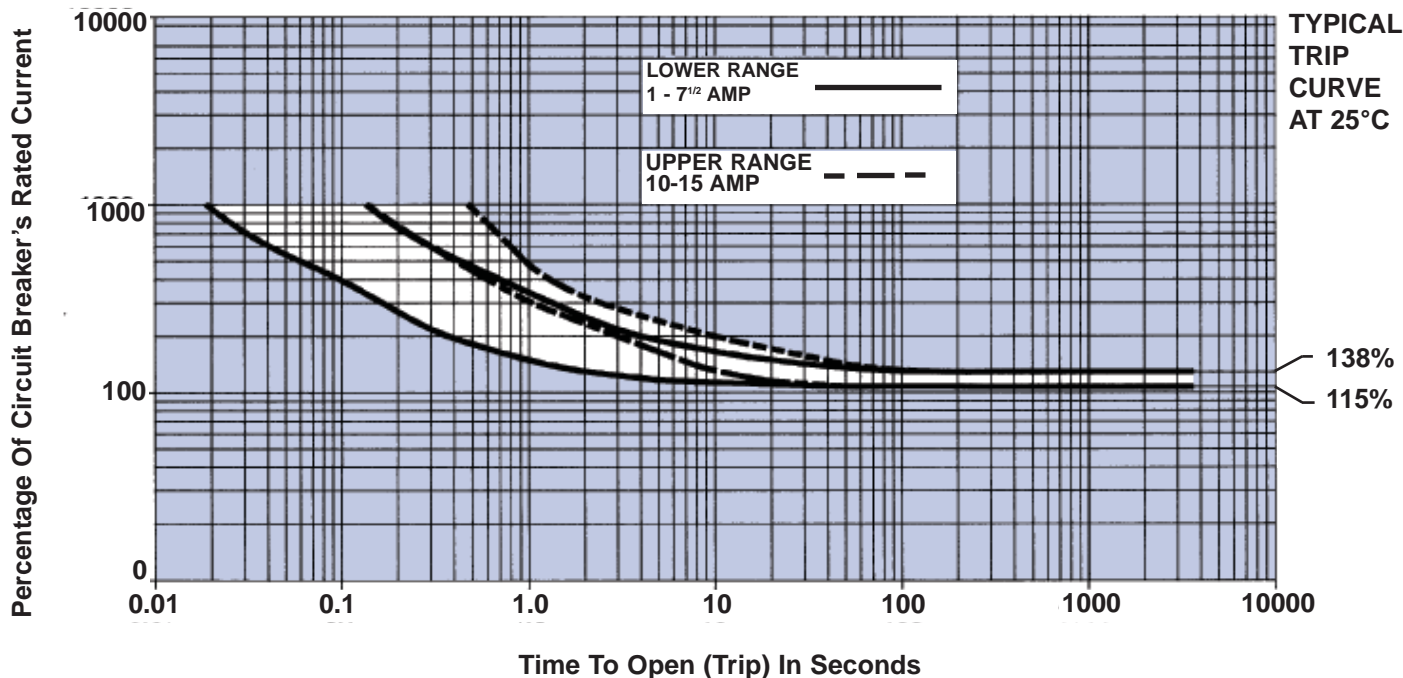



**Three-Pole High Performance**

**Three-Phase Protection**

Common trip mechanism trips all three phases, regardless of which phase is overloaded.

**Integral Barriers**

Terminals are separated by barriers molded into the case.

**Single-Hole Mounting**

For quick, easy installation.

**Shock And Vibration Resistant Construction**

Permits use in various types of portable and mobile airborne equipment.

**Performance Rated Circuit Breaker**

The 1536-001 is a lightweight, miniature breaker that features three bimetal sensing elements having very fast electro-dynamic response under short circuit conditions, and standard trip characteristics at lower levels of overloads.

Single hole mounting and small size facilitate easy installation. The breaker's one-piece, glass-filled case features integrally-molded barriers to separate the terminals.

**PERFORMANCE DATA**

<b>Interrupting Capacity</b>	1,000A at 205V, 400 Hz., three-phase symmetrical fault 1,000A at 120V, 400 Hz., single-phase fault
<b>Endurance</b>	At 120VAC, 400 Hz.: inductive load — 5,000 cycles; resistive load — 5,000 cycles; mechanical cycling, no load — 5,000 cycles
<b>Overload Cycling</b>	100 operations at 200% load
<b>Dielectric Strength</b>	1,500V, minimum
<b>Insulation Resistance</b>	Not less than 100 megohms at 500V, DC
<b>Voltage Drop</b>	Varies with rating (see "Ordering Information")
<b>Vibration</b>	Exceeds MIL-STD-202, Method 204, Condition A
<b>Shock</b>	Exceeds 30G's, 11 Millisec (half-sine pulse) MIL-STD-202, Method 213 Test J
<b>Acceleration</b>	Exceeds 10G's
<b>Weight</b>	181 grams (.40 lbs.)

**OVERLOAD CALIBRATION DATA**

Specification Table	@ 25°C		@ +71°C		@ -55°C		Test Time Parameters
	MIN	MAX	MIN	MAX	MIN	MAX	
Must Hold	105	—	70	—	130	—	% For 1 Hour
Must Trip	—	138 Balanced*	—	110	—	160	% Within 1 Hour
200% Overload	10.00	70.0	—	—	—	—	Seconds
400% Overload	2.00	10.0	—	—	—	—	Seconds
600% Overload	1.00	4.0	—	—	—	—	Seconds
1000% Overload	0.35	1.4	—	—	—	—	Seconds

\* Unbalanced load, individual phases: 145%  
Trip curve available.

**ORDERING INFORMATION**

Ampere Rating	Voltage Drop Max.*	Part Number
5	0.350	1536-001-5
7 1/2	0.325	1536-001-705
10	0.300	1536-001-10
15	0.250	1536-001-15
20	0.200	1536-001-20
25	0.180	1536-001-25
30	0.180	1536-001-30
35	0.175	1536-001-35
40	0.175	1536-001-40
50	0.150	1536-001-50

\* At rated nominal current.  
For other amperage ratings and configurations, consult the Business Unit.

DIMENSIONS

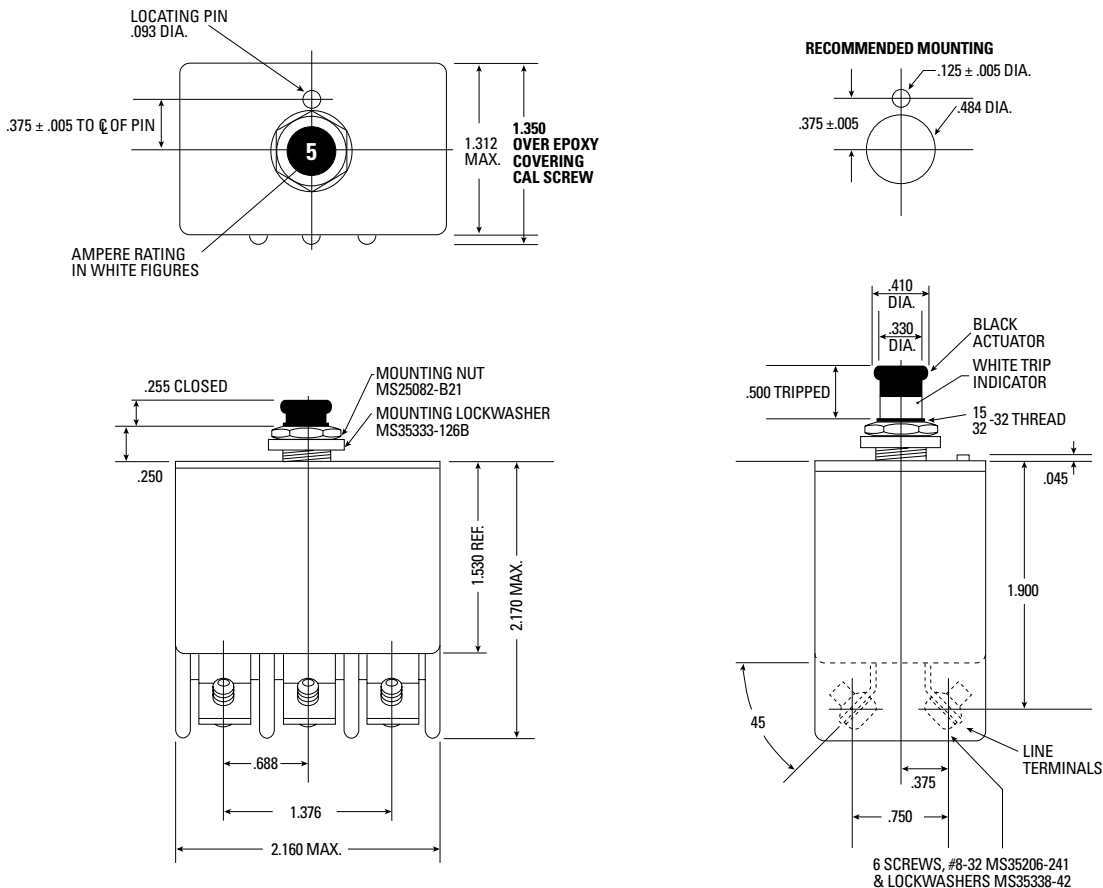

TRIP CURVE

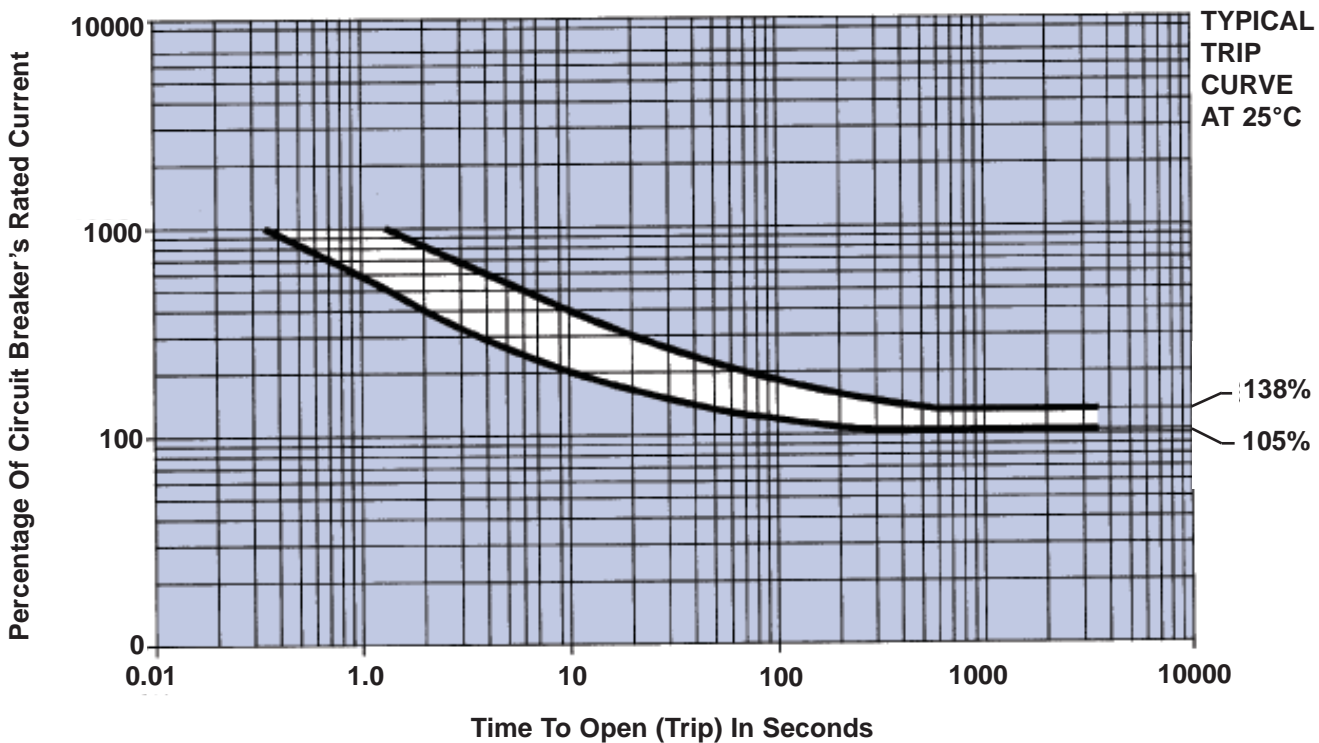



**Standard**

The space-qualified product utilizes the same internal design.

**Three-Phase Protection**

**Qualified**

To MS14154 of MIL-C-5809.

**Lightweight**

Weighs 68 grams maximum (0.15 lbs).

**Vibration Resistance**

Vibration resistance and mechanical life exceed MIL Specs — including random vibration.

**Miniature Size — High Performance**

19.8mm, 46.7mm, 35.0mm behind panel depth.

**Temperature-Compensated**

Ambient-temperature-compensated from -55°C to +71°C. Note: higher operating ranges are available.

**Performance Rated Circuit Breaker**

This lightweight, miniature, three-phase circuit breaker, Series 4330, reflects the latest advancements in circuit breaker design, incorporating self-wiping contacts, tight tolerances in design, and stringent manufacturing standards. It is fungus-proof and highly resistant to corrosion. The trip-free thermal mechanism avoids nuisance trips (even during temporary surges of starting loads) under ambient temperatures ranging from -55°C to +71°C. Calibration integrity is maintained through wide variations in ambient temperature and altitude, making this circuit breaker ideal for applications where temperature is not controlled.

**Multiple Options**

This series is available in many optional configurations.

*It is presently being manufactured with 7/16, 15/32 and metric mounting sleeves. Many versions of different terminals, barriers, and hardware are current production items. Several different button options provide our customers with additional flexibility.*

**PERFORMANCE DATA**

<b>Interrupting Capacity</b>	1,200A balanced at 205V, 400Hz, AC and 2,000A unbalanced at 120V, 400Hz, AC, at sea level and 70,000 feet
<b>Endurance</b>	120V, 400 Hz., AC: inductive load — 2,500 cycles; resistive load — 5,000 cycles; mechanical cycling no load — 5,000 cycles
<b>Overload Cycling</b>	100 cycles at 200%
<b>Dielectric Strength</b>	At sea level, 25°C 1,500V, AC. At 70,000 ft. +71°C 500V, AC
<b>Insulation Resistance</b>	Not less than 100 megohms at 500V, DC
<b>Voltage Drop</b>	Varies with rating (see "Ordering Information")
<b>Vibration</b>	Meets specification MIL-STD-202, Method 204, Condition A-10G., 10-500 Hz. MS "V" type, meets Condition B, 15G, 10-2,000 Hz. and Condition C 10G, 10-2,000 Hz.
<b>Shock</b>	50G's. MIL-STD-202, Method 213 Test G
<b>Acceleration</b>	Exceeds 10G's
<b>Weight</b>	68 grams max. (0.15 lbs.)

**OVERLOAD CALIBRATION DATA**

Specification Table	@ 25°C		@ +71°C		@ -55°C		Test Time Parameters
	MIN	MAX	MIN	MAX	MIN	MAX	
Must Hold	110	—	100	—	110	—	% For 1 Hour
Must Trip	—	145	—	145	—	165	% Within 1 Hour
200% Overload	4.00	20.00	3.00	20.00	6.00	40.00	Seconds
500% Overload	0.40	2.00	0.33	1.70	0.55	3.50	Seconds
1000% Overload	0.10	0.53	0.08	0.40	0.15	0.80	Seconds

**ORDERING INFORMATION**

MS APPROVAL STATUS	AMPERE RATING	VOLTAGE DROP MAX.*	STANDARD		LONG BUTTON		HIGH VIBRATION		LONG BUTTON VIBRATION	
			MS P/N	EATON MP P/N	MS P/N	EATON MP P/N	MS P/N	EATON MP P/N	MS P/N	EATON MP P/N
MS Approved	1	1.10	MS14154-1	4330-001-1	MS14154-1L	4330-007-1	MS14154-1V	4330-008-1	MS14154-1VL	4330-009-1
MS Approved	2	0.75	MS14154-2	4330-001-2	MS14154-2L	4330-007-2	MS14154-2V	4330-008-2	MS14154-2VL	4330-009-2
MS Approved	2 1/2	0.70	MS14154-2 1/2	4330-001-205	MS14154-2 1/2L	4330-007-205	MS14154-2 1/2V	4330-008-205	MS14154-2 1/2VL	4330-009-205
MS Approved	3	0.55	MS14154-3	4330-001-3	MS14154-3L	4330-007-3	MS14154-3V	4330-008-3	MS14154-3VL	4330-009-3
MS Approved	4	0.45	MS14154-4	4330-001-4	MS14154-4L	4330-007-4	MS14154-4V	4330-008-4	MS14154-4VL	4330-009-4
MS Approved	5	0.35	MS14154-5	4330-001-5	MS14154-5L	4330-007-5	MS14154-5V	4330-008-5	MS14154-5VL	4330-009-5
MS Approved	7 1/2	0.30	MS14154-7 1/2	4330-001-705	MS14154-7 1/2L	4330-007-705	MS14154-7 1/2V	4330-008-705	MS14154-7 1/2VL	4330-009-705
MS Approved	10	0.28	MS14154-10	4330-001-10	MS14154-10L	4330-007-10	MS14154-10V	4330-008-10	MS14154-10VL	4330-009-10
MS Approved	15	0.28	MS14154-15	4330-001-15	MS14154-15L	4330-007-15	MS14154-15V	4330-008-15	MS14154-15VL	4330-009-15
MS Approved	20	0.25	MS14154-20	4330-001-20	MS14154-20L	4330-007-20	MS14154-20V	4330-008-20	MS14154-20VL	4330-009-20

\* AT RATED NOMINAL CURRENT  
For other amperage ratings and configurations, consult the Business Unit.

**DIMENSIONS**

MIL Spec	Part No.	A*Max.	B*Min.
MS14154	4330-001	0.750	0.470
MS14154L	4330-007	1.125	0.845
MS14154V	4330-008	0.750	0.470
MS14154VL	4330-009	1.125	0.845

Min. Panel Thickness .025  
 Max. Panel Thickness .100

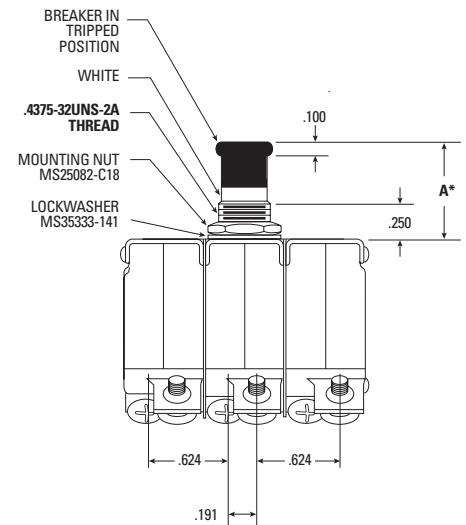
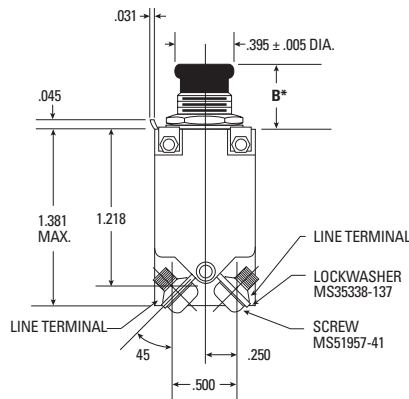
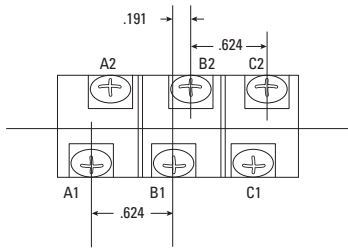
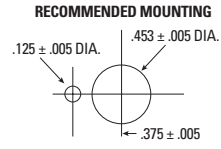
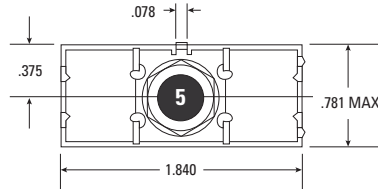

**TRIP CURVE**

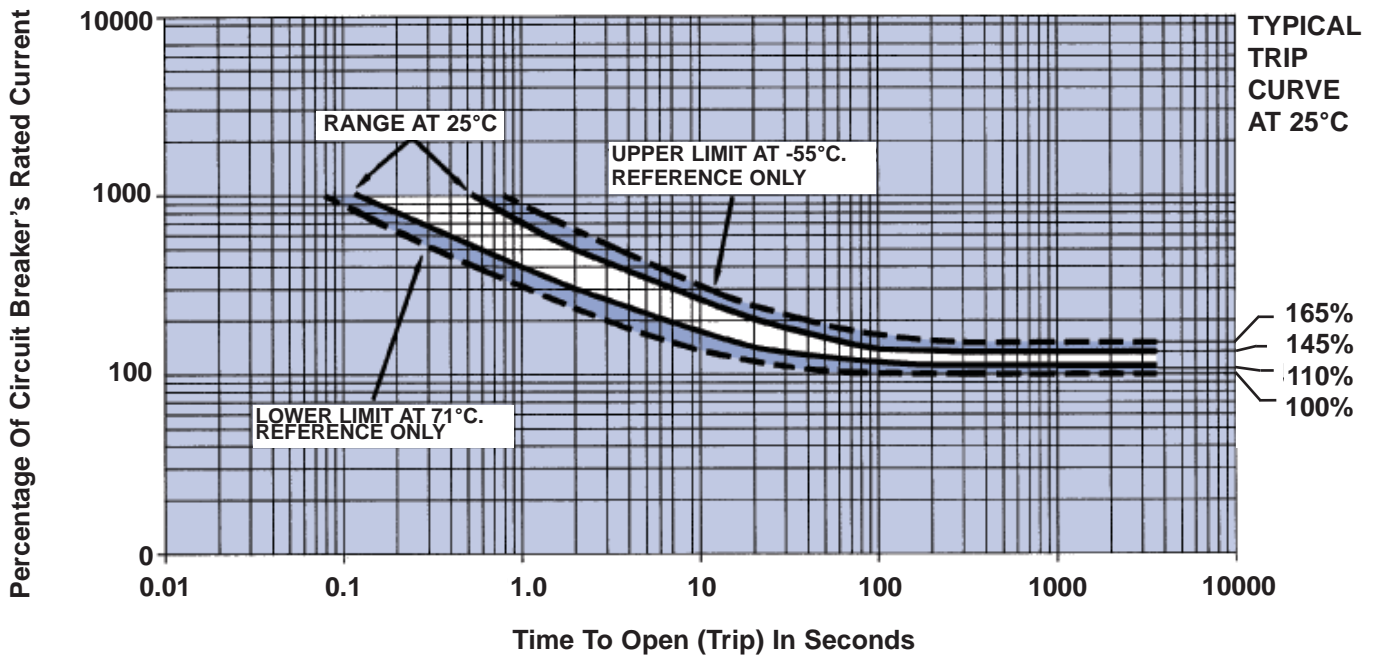

# Remote Controlled Circuit Breaker (RCCB)



## Single Phase

- 28 VDC
- 115/200 VAC 400 Hz



## Three Phase

- 115/200 VAC 400 Hz
- Three Phase Only

## Qualified

Qualified to demanding performance parameters of MIL-PRF - 83383 standard.

## Use as a Relay, Circuit Breaker, Or Both

RCCBs combine the best attributes of a circuit breaker and a relay. Automatically protects the wires and the load device during circuit/load breakdown, but allows the flight deck control of the load during normal operation.

## Weight and Cost Savings

In distributed-load applications, RCCBs are a more efficient power distribution solution promoting cost and weight savings through the elimination of long runs of heavy cables associated with the conventional relay - flight deck circuit protector method. Control of the RCCB requires only one #22 AWG control wire from the ICU on the flight deck to the RCCB.

## Cockpit Space Savings

An RCCB system removes the presence of large circuit breakers from the cockpit while permitting remote On/Off operation from the flight deck. Combine Eaton RCCB with Indicator Control Unit (ICU) model #1500-053-05.

## PERFORMANCE DATA

<b>Rupture Levels</b>	3600 A (115 VAC or 28VDC for 1 Pole and 115VAC for 3 Pole)
<b>Endurance (Resistive &amp; Inductive(Motor))</b>	50,000 Cycles
<b>Endurance (Motor)</b>	5-50A: 50,000 cycles; 60-100A: 25,000 cycles
<b>Endurance (Lamp)</b>	5-25A: 50,000 cycles; 35-50A: 25,000 cycles; 60-100A: no rating
<b>Dielectric Strength</b>	1500V, 60Hz, MIL-STD-202, method 301, 0.5 MA max
<b>Insulation Resistance</b>	100 mega ohm min, MIL-STD-202, method 302
<b>Thermal Temperature Range</b>	-54°C to 71°C (-65°F to 160°F). MIL-STD-202, Method 107
<b>Vibration</b>	10G's to 2000 Hz. Exceeds MIL-STD-202, Method 204, Condition C, 10 microseconds max. chatter
<b>Shock</b>	25G's. MIL-STD-202, Method 213, 10 microseconds max. chatter
<b>Altitude</b>	50,000 ft.
<b>EMI Requirements</b>	MIL-STD-461, Requirements CS114 and RE102 over the frequency range of 14 KHz to 400 MHz and RE102 limits for Aircraft and Space Systems.
<b>EMI/RFI Susceptibility and Generation</b>	MIL-STD-461, Class 1D
<b>Moisture Resistance</b>	MIL-STD-202, method 106
<b>Salt Spray Resistance</b>	MIL-STD-202, method 101, Condition B
<b>Sand and Dust Resistance</b>	MIL-STD-202, method 110, Condition A
<b>Fungus Resistance</b>	MIL-HDBK-454, Guideline 4
<b>Explosion Proof</b>	MIL-STD-202, method 109
<b>Weight (Standard)</b>	5-25A: 318 grams (0.703 lbs.); 35-50A: 325 grams (0.719 lbs.); 60-100A: 332 grams (0.734 lbs.)
<b>Weight (w/ Auxiliary Contacts)</b>	5-25A: 332 grams (0.734 lbs.); 35-50A: 339 grams (0.750 lbs.); 60-100A: 346 grams (0.766 lbs.)

## OVERLOAD CALIBRATION DATA

Specification Table	@ 25°C		@ +71°C		@ -54°C		Test Time Parameters
	MIN	MAX	MIN	MAX	MIN	MAX	
Must Hold	115%		115%		115%		% for 1 Hour
Must Trip		138%		138%		150%	% Within 1 Hour

## ORDERING INFORMATION

AMPERE RATING	Single Pole Single Throw (Double Break Contacts)				Three Pole Single Throw (Double Break Contacts)	
	Standard		w/ Auxiliary Contacts		w/ Auxiliary Contacts	
	MS P/N	EATON P/N	MS P/N	EATON P/N	MS P/N	EATON P/N
5	M83383/01-01	SM600BA5N1	M83383/02-01	SM600BA5A1		**
7.5		**		**		**
10	M83383/01-03	SM600BA10N1	M83383/02-03	SM600BA10A1	M83383/04-03	SM601BA10A1
15	M83383/01-04	SM600BA15N1	M83383/02-04	SM600BA15A1		SM601BA15A1
20	M83383/01-05	SM600BA20N1	M83383/02-05	SM600BA20A1	M83383/04-05	SM601BA20A1
25	M83383/01-06	SM600BA25N1	M83383/02-06	SM600BA25A1		SM601BA25A1
35	M83383/01-07	SM600BA35N1	M83383/02-07	SM600BA35A1	M83383/04-07	SM601BA35A1
40	M83383/01-08	SM600BA40N1	M83383/02-08	SM600BA40A1	M83383/04-08	SM601BA40A1
50	M83383/01-09	SM600BA50N1	M83383/02-09	SM600BA50A1		SM601BA50A1
60	* M83383/01-10	SM600BA60N1	M83383/02-10	SM600BA60A1	M83383/04-10	SM601BA60A1
75	* M83383/01-11	SM600BA75N1	M83383/02-11	SM600BA75A1		
80	*	**		**		
100	* M83383/01-13	SM600BA100N1	M83383/02-13	SM600BA100A1		

All Ampere Ratings equal to Rated Contact Loads (Resistive, Inductive, Motor, and Lamp) except as noted.

\* No Lamp Load Rating

\*\* Contact Business Unit

Note: Contact Business unit on Alternate Amperages, Trip Times, Control Configurations, Grounding, Auxiliary Switches, Mounting Systems, etc.

# Remote Controlled Circuit Breaker (RCCB)

## OVERLOAD CALIBRATION DATA - SINGLE POLE

AMPERE RATING	200% Trip Times -54°C to +71°C		400% Trip Times -54°C to +71°C		1000% Trip Times -54°C to +71°C	
	MIN	MAX	MIN	MAX	MIN	MAX
	SECONDS	SECONDS	SECONDS	SECONDS	SECONDS	SECONDS
5	7	40	1.2	6.4	0.3	1.2
7.5	11	40	2.4	6.8	0.33	1.1
10	12	42	2.8	8.5	0.42	1.05
15	13	45	1.7	8.3	0.35	1.2
20	14	46	2.9	7.6	0.4	1.15
25	15	50	2.6	8.7	0.4	1.3
35	16	55	2.8	8.3	0.35	1.3
40	16	55	2.9	9.2	0.36	1.3
50	13	55	2.9	10	0.4	1.25
60	13	60	2.6	13	0.26	1.8
75	13	60	2.5	13	0.26	1.8
80	14	60	2.7	12.5	0.3	2
100	17	63	3.5	13	0.38	1.9

## OVERLOAD CALIBRATION DATA - THREE POLE

AMPERE RATING	200% Trip Times -54°C to +71°C		400% Trip Times -54°C to +71°C		1000% Trip Times -54°C to +71°C	
	MIN	MAX	MIN	MAX	MIN	MAX
	SECONDS	SECONDS	SECONDS	SECONDS	SECONDS	SECONDS
10	12	80	2.8	11	0.42	1.3
15	13	80	1.7	10	0.35	1.2
20	14	80	2.9	9.6	0.4	1.15
25	15	80	2.6	10	0.4	1.3
35	16	80	2.8	11	0.35	1.3
40	16	80	2.6	10	0.36	1.3
50	13	80	2.9	10	0.4	1.25
60	13	80	2.4	16	0.26	1.8

## TRIP CURVE

Contact business unit for trip curve.

# Remote Controlled Circuit Breaker (RCCB)

## 1 Pole and 3 Pole

### Engineering Data

#### Application Note

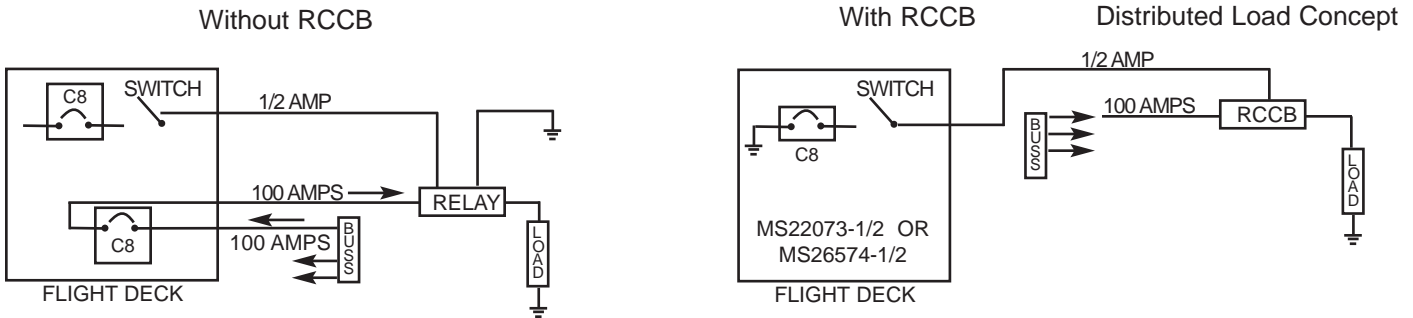

### Typical Wiring Diagram

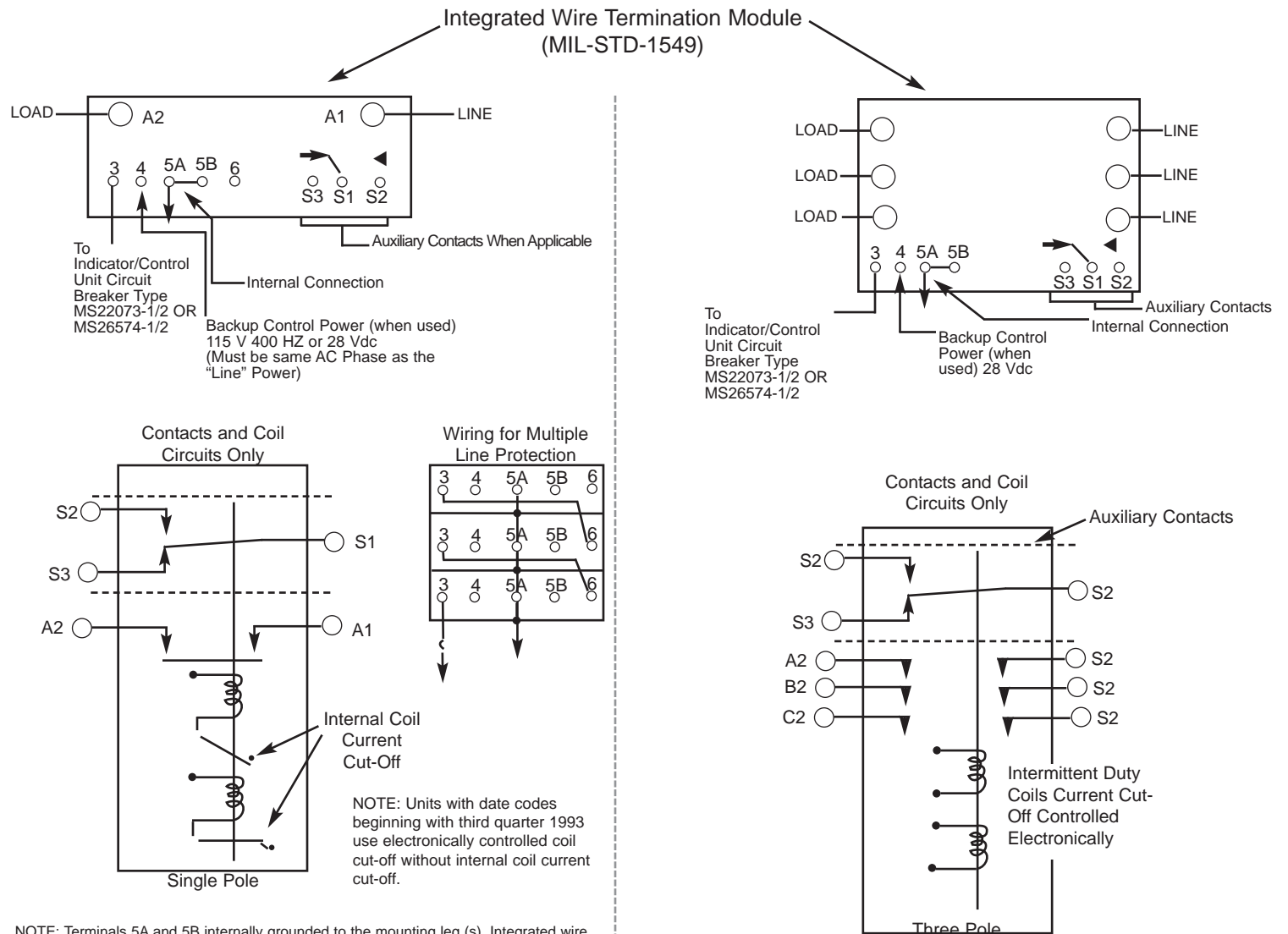

NOTE: Terminals 5A and 5B internally grounded to the mounting leg (s). Integrated wire termination (IWT) module accepts pin contacts P/N M39029/1-100 or -101. Use with insertion/extraction tool M81969/14-02.

# Remote Controlled Circuit Breaker (RCCB) 1 Pole and 3 Pole

## Engineering Data

### Approximate Dimensions - 1 Pole

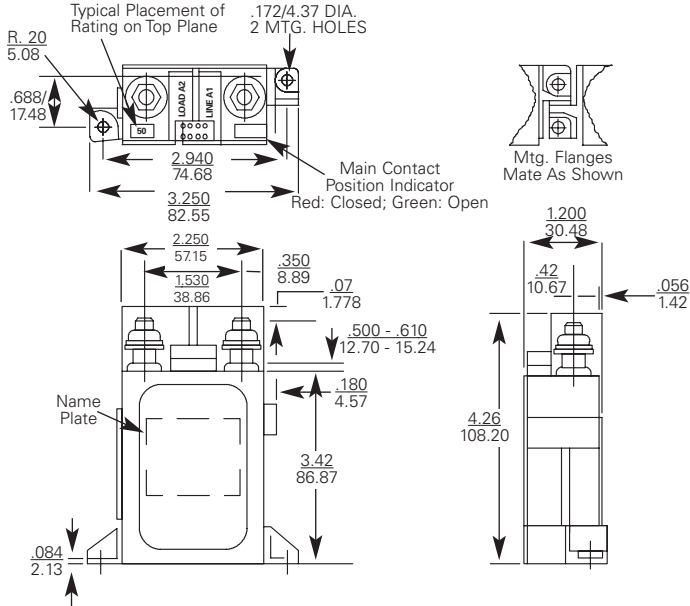

### Options

- Special application auxiliary switches
- Unique grounding
- Power sources
- Other current ratings
- Control via systems other than I/CU
- Low level auxiliary contacts available
- Data Bus/Interface capability available
- Electronically held coil

### 3Pole

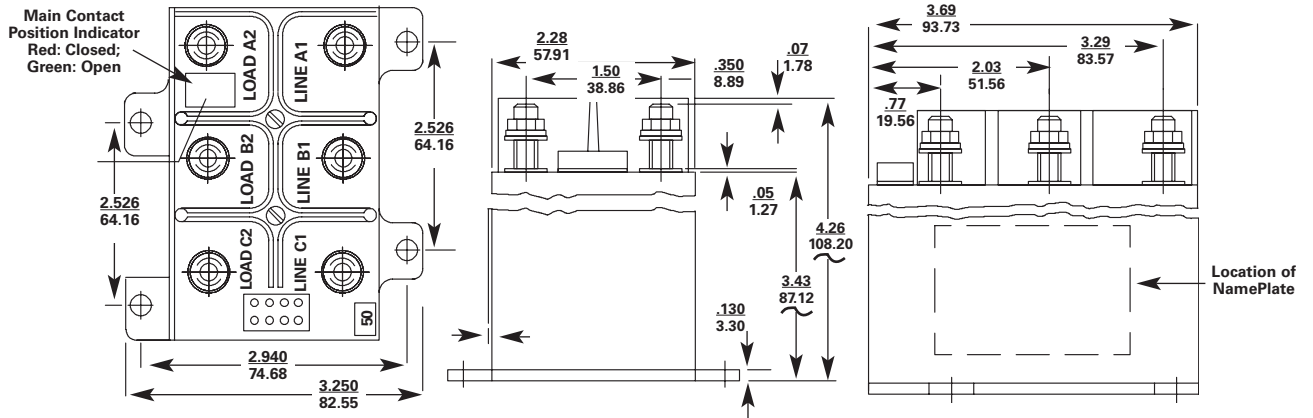

### Coil Operate Current/Set And Trip Time RCCB

Circuits	Nominal System Voltage	I/CU Set Current @ Nom Voltage (Mulliamp)	Set Coil Current @ Nom Voltage Pulse	MAX. Set Time		*I/CU. Trip Current Nominal					MAX. Standby Current Milliamp
				Nominal Voltage & Room Temp.	Most Adverse Condition - MIN. Voltage 71°C. Ambient	71°C & Nominal Voltage	-54°C & Nominal Voltage	Room Temp. Nominal Voltage	71°C & Nominal Voltage	-54°C & Nominal Voltage	
1 Pole	28 Vdc (18 Volts MIN.)	2	3.0 AMP MAX	20 Millisec	35 Millisec	1.4 AMP	1.9 AMP	1.6 AMP	0.9 AMP ***	2.1 AMP	10
	115 Vac 400 Hz (104 V. MIN.)	2	10 AMP MAX	15 Millisec	30 Millisec	6.8 AMP **	6.3 AMP **	8.6 AMP **	6.1 AMP **	7.0 AMP **	10
3 Pole	28 Vdc (18 Volts MIN.)	2	7.0 AMP MAX	20 Millisec	35 Millisec	1.5 AMP	2.0 AMP	1.7 AMP	0.9 AMP ***	2.2 AMP	10
	115 Vac 400 Hz (104 V. MIN.)	2	13.0 AMP MAX	15 Millisec	30 Millisec	4.3 AMP **	3.3 AMP **	4.5 AMP **	4.0 AMP **	3.1 AMP **	10

\* MAX. I/CU. Line Impedance 75  
\*\* Average Half-Wave Rectified DC Current

Current Decreases w/Time so that  $I^2t$   
\*\*\*Absolute Min. Value from -54° to +71°C

# Remote Power Controller (RPC)



Single Pole  
• 28 VDC

## Electronic Current Sensing

The electronic over current sensing of these devices offer several advantages over the bi-metal sensing RCCB. Trip current levels can be closely controlled, for better protection of sensitive loads, trip times are faster, and both can be customized for specific applications. Other advantages included less heat buildup, and higher current capabilities in the same small package.

## Use as a Relay, Circuit Breaker, Or Both

RPCs, like RCCBs, combine the best attributes of a circuit breaker and a relay. Automatically protects the wires and the load device during circuit/load breakdown, but allows the flight deck control of the load during normal operation.

## Weight and Cost Savings

In distributed-load applications, RPCs are a more efficient power distribution solution promoting cost and weight savings through the elimination of long runs of heavy cables associated with the conventional relay - flight deck circuit protector method. Control of the RPC requires only one #22 AWG control wire from the ICU (model #1500-053-05) on the flight deck to the RPC.

## PERFORMANCE DATA

<b>Rupture Levels</b>	2500 A (28V <sub>DC</sub> )
<b>Endurance (Resistive)</b>	50,000 Cycles
<b>Endurance (Inductive and Motor)</b>	25,000 cycles
<b>Endurance (Lamp)</b>	No Rating
<b>Mechanical Life</b>	100,000 cycles
<b>Dielectric Strength</b>	Sea Level - VRMS .2-3 seconds: Coil to Case - 1250 initial, 1,000 After Life, All other Points 1,800 Initial, 1350 After Life 50,000 Ft. - VRMS 1 Minute: Coil to Case 500 Initial & After Life, All other Points 700 Initial & After Life
<b>Insulation Resistance</b>	1100 Megohms initial, 50 Megohms after Life, MIL-STD-202, method 302, test condition B
<b>Thermal Temperature Range</b>	-55°C to 85°C (-67°F to 185°F)
<b>Vibration</b>	Sinusoidal 5 to 10 Hz: 0.08 DA; 10 TO 55 Hz: 0.06 DA; 55 to 2000 Hz: 10G's
<b>Shock</b>	50G's. (1/2 sine, 10-12 ms)
<b>Altitude</b>	50,000 Ft. Maximum
<b>EMI Requirements</b>	MIL-STD-461, Requirements CS114 and RE102 over the frequency range of 14 KHz to 400 MHz and RE102 limits for Aircraft and Space Systems
<b>Moisture Resistance</b>	MIL-STD-202, method 106
<b>Salt Spray Resistance</b>	MIL-STD-202, method 101, Condition B
<b>Sand and Dust Resistance</b>	MIL-STD-202, method 110, Condition A
<b>Fungus Resistance</b>	MIL-HDBK-454, Guideline 4
<b>Explosion Proof</b>	MIL-STD-202, method 109
<b>Weight (Standard)</b>	425.017 grams (0.937 lbs.)

## OVERLOAD DATA

% Rated Current	Trip in Seconds - 55°C to +85°C
100%	No Trip
125%	45 Sec. Trip
200%	0.22 Sec. Trip
400%	0.095 Sec. Trip

## ORDERING INFORMATION

### Single Pole Single Throw (Double Break Contacts)

AMPERE RATING	EATON P/N	Rated Contact Load (Amperes) 28VDC			
		Res.	Ind.	Motor	Min.
125	SM600BA125A1	125	125	125	5
150	SM600BA150A1	150	150	150	5
175	SM600BA175A1	175	150	175	5
200	SM600BA200A1	200	150	175	5

#### Notes:

- One auxiliary contact included on each unit
- Contact Business Unit on Alternate Amperages, Trip Times, Control Configurations, Grounding, Auxiliary Switches, Mounting Systems, etc.

## Engineering Data

### Approximate Dimensions - 1 Pole

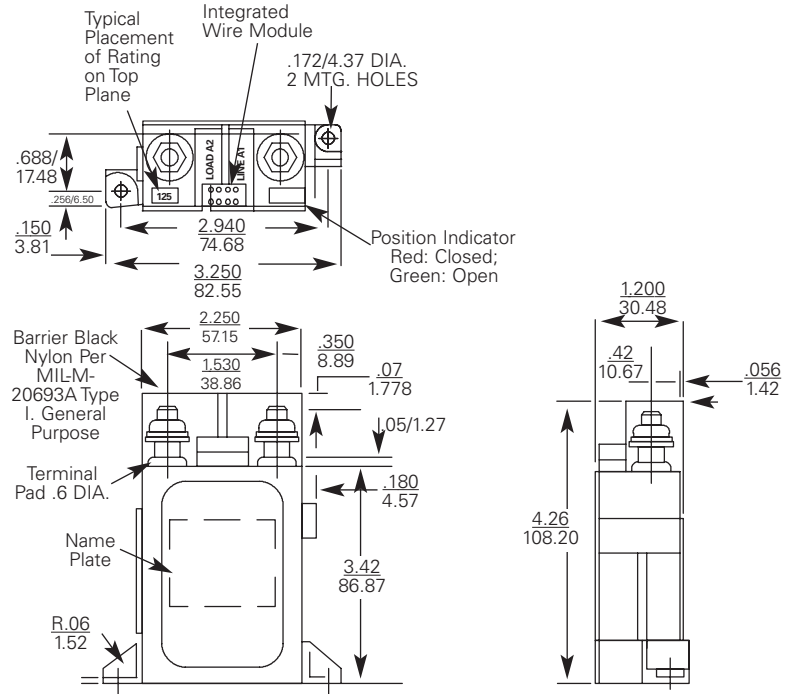

## Typical Wiring Diagram

### Approximate Dimensions

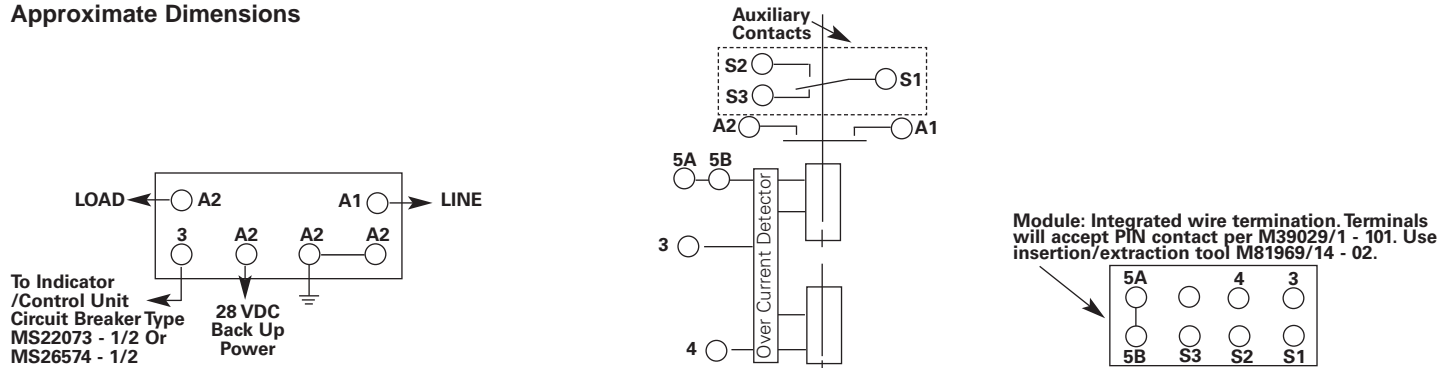

### COIL OPERATE CURRENT/SET AND TRIP TIME

Nominal System Voltage	I/C Set Current @ Nom. Voltage (milliamp)	Set Coil Current @ Nom Voltage Pulse	MAX. Set Time		*I/CU. Trip Current Nominal			
			Nominal Voltage @ Room Temp	Most Adverse Condition-Min. Voltage 71°C Ambient	71°C and Nominal Voltage	-54°C and Nominal Voltage	Room Temp and Nominal Voltage	Max. Standby Current (milliamp)
28 VDC (18 Volts Min)	2	3.7 Amp	20 Millisec	35 Millisec	1.76 Amp	1.25 Amp	1.89 Amp	30

\* MAX I/CU. LINE IMPEDANCE 75 Ohms

CURRENT DECREASES W/TIME SO THAT  $I^2t \geq 2$

## Additional Products



### Additional Series

In addition to the circuit breaker products described in this catalog, Eaton Aerospace has the capability to manufacture over twenty additional series of circuit breakers. Please contact the Business Unit at 1-800-955-7354 for details or ordering information on these unique devices.

Series 60  
 Series 100  
 Series 130  
 Series 140  
 Series 180  
 Series 260  
 Series 270  
 Series 780  
 Series 920  
 Series 930  
 Series 960  
 Series 970  
 Series 1200  
 Series 1538  
 Series 1540  
 Series 1585  
 Series 2100  
 Series 4380  
 Series 8500  
 Series 9500

### Additional Product Design Options

If your application calls for an amperage, feature, or option we do not currently list in our catalog, please contact the Business Unit at 1-800-955-7354.

## Accessories

### Rubber Boot Assembly

- Seals button from outside contaminants
- Removable
- Fits standard length buttons
- Includes boot, nut, and o'ring

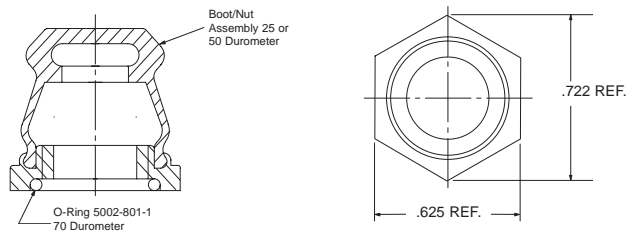

### Boot Assembly Ordering Information

Series	Part Numbers		Thread Size
	Boot Durometer = 25	Boot Durometer = 50	
700	5002-411-4	5002-411-2	15/32
1500	5002-411-4	5002-411-2	15/32
1526	5002-411-4	5002-411-2	15/32
1536	5002-411-4	5002-411-2	15/32
4001	5002-411-4	5002-411-2	15/32
4200	5002-411-3	5002-411-1	7/16
4310	5002-411-3	5002-411-1	7/16
4330	5002-411-3	5002-411-1	7/16

**Ambient Compensation**

Limits or eliminates thermal derating (lowering of capabilities) caused by extreme ambient temperatures.

**Ambient Temperature**

Refers to the temperature of the air immediately surrounding the circuit breaker/protection device.

**Automatic Reset**

Device that will automatically open an overload circuit. It will also automatically close or complete the circuit after a period of time. If the overload is still present, the device will continue to cycle until either the power or the overload is removed.

**Circuit Breaker**

Device designed to open and close a circuit manually and to open the circuit automatically on a predetermined overload of current.

**Current Rating**

Designation of rating given in amperes at which the device will not trip. A specific temperature is usually assigned.

**Dielectric Strength**

The ability of an insulating material to withstand an over voltage without exceeding minimal leakage current levels or material breakdown. Specified in voltage (VAC), usually between a live metal part and ground or between open contacts of a device.

**Fuse**

A protective device using a special metal-alloyed conductor that is often notched or otherwise engineered to control the cross sectional area. A fault current will melt the narrow cross section, interrupting the flow of current.

**Fusible Link/Fail Safe**

A metallic sacrificial element within the RCCB or circuit breaker that melts and then arcs due to the joule heating of an over current. This feature ensures that a fault cannot cause the RCCB or circuit breaker to fail in the closed position.

**Interrupt Capacity**

The highest level of fault current that a circuit protective system is intended to interrupt.

Depending on qualification requirements, some devices must clear the fault, be operable afterwards, and still be capable of tripping on 200 percent overloads. While other qualified devices may have a backup device wherein the combination must successfully clear the fault while leaving the protector in a fail-safe condition (no loss of case integrity, external materials remaining unignited by gaseous emissions, and no dielectric path to grounded parts).

**Manual Reset**

Refers to breakers in which the electrical contacts remain open after a trip until someone physically closes or completes the circuit by either pushing a reset button or throwing a switch.

**Maximum Ultimate Trip (must trip)**

Current rating at which a circuit protection device will trip within a certain period of time at a specified temperature.

**Minimum Ultimate Trip (must hold)**

Current rating for which a circuit protection device will not trip for an extended period of time at a specified temperature.

**Nuisance Trips**

Those trips caused by a response to non-damaging inrush or start-up current surges, as opposed to an actual overcurrent trip.

**Overcurrent**

That current which may cause dangerous overheating.

**Overcurrent Protection**

Protection achieved by limiting the duration and magnitude of exposure to an overcurrent.

**Overload**

An electrical load or current flow greater than that which a circuit is designed to handle.

**Overload Capacity**

The highest level of overload current that devices will interrupt and remain in operable condition, capable of clearing additional overloads.

**Safety Factor**

The allowance added to the steady-state application current to ensure that the protective device selected will be more

than sufficient to handle the application without nuisance trips. Eaton recommends a minimum safety factor of 15 percent.

**Slow-Blow Fuse**

A dual element fuse that allows for slow response to overloads (less than 10x rating) and fast response to fault currents.

**Trip-Free**

A characteristic of certain breakers that provides independence between the protection mechanism and the operating button or handle, such that a fault cannot be maintained manually (or held closed) against an overload.

**Trip Indication**

Visual sign the breaker has opened.

**Trip Curve**

Graphic displaying minimum and maximum time a breaker takes to trip for given levels of overload.

**Voltage Drop**

The voltage decreases across the protector/breaker due to the internal resistance of the device.

# Qualified Products Under Military Specification for MIL-C-8509 And MIL-C-83383

MS P/N	EATON P/N	Page	MS P/N	EATON P/N	Page	MS P/N	EATON P/N	Page	MS P/N	EATON P/N	Page
<b>MIL-C-8509</b>			MS14154-4VL	4300-009-4	32	MS25244-30	700-001-30	16	MS26574-10A	4200-004-10	22
MS3320-1	4310-001-1	24	MS14154-5	4330-001-5	32	MS25244-35	700-001-35	16	MS26574-10L	4200-003-10	22
MS3320-1L	4310-005-1	24	MS14154-5L	4330-007-5	32	MS25244-P5	700-089-5	16	MS26574-15	4200-001-15	22
MS3320-1V	4310-019-1	24	MS14154-5V	4330-008-5	32	MS25244-P7 1/2	700-089-705	16	MS26574-15A	4200-004-15	22
MS3320-1VL	4310-024-1	24	MS14154-5VL	4330-009-5	32	MS25244-P10	700-089-10	16	MS26574-15L	4200-003-15	22
MS3320-2	4310-001-2	24	MS14154-7 1/2	4330-001-705	32	MS25244-P15	700-089-15	16	MS26574-20	4200-001-20	22
MS3320-2L	4310-005-2	24	MS14154-7 1/2L	4330-007-705	32	MS25244-P20	700-089-20	16	MS26574-20A	4200-004-20	22
MS3320-2V	4310-019-2	24	MS14154-7 1/2V	4330-008-705	32	MS25244-P25	700-089-25	16	MS26574-20L	4200-003-20	22
MS3320-2VL	4310-024-2	24	MS14154-7 1/2VL	4330-009-705	32	MS25244-P30	700-089-30	16	MS26574-D3/4	4200-006-075	22
MS3320-2 1/2	4310-001-205	24	MS14154-10	4330-001-10	32	MS25244-P35	700-089-35	16	MS26574-D3/4L	4200-007-075	22
MS3320-2 1/2L	4310-005-205	24	MS14154-10L	4330-007-10	32	MS25244-PT5	700-092-5	16	MS26574-D1	4200-006-1	22
MS3320-2 1/2V	4310-019-205	24	MS14154-10V	4330-008-10	32	MS25244-PT7 1/2	700-092-705	16	MS26574-D1L	4200-007-1	22
MS3320-2 1/2VL	4310-024-205	24	MS14154-10VL	4330-009-10	32	MS25244-PT10	700-092-10	16	MS26574-D1 1/2	4200-006-105	22
MS3320-3	4310-001-3	24	MS14154-15	4330-001-15	32	MS25244-PT15	700-092-15	16	MS26574-D1 1/2L	4200-007-105	22
MS3320-3L	4310-005-3	24	MS14154-15L	4330-007-15	32	MS25244-PT20	700-092-20	16	MS26574-D2	4200-006-2	22
MS3320-3V	4310-019-3	24	MS14154-15V	4330-008-15	32	MS25244-PT25	700-092-25	16	MS26574-D2L	4200-007-2	22
MS3320-3VL	4310-024-3	24	MS14154-15VL	4330-009-15	32	MS25244-PT30	700-092-30	16	MS26574-D2 1/2	4200-006-205	22
MS3320-4	4310-001-4	24	MS14154-20	4330-001-20	32	MS25244-PT35	700-092-35	16	MS26574-D2 1/2L	4200-007-205	22
MS3320-4L	4310-005-4	24	MS14154-20L	4330-007-20	32	MS25361-50	160-012-50	12	MS26574-D3	4200-006-3	22
MS3320-4V	4310-019-4	24	MS14154-20V	4330-008-20	32	MS25361-50V	160-086-50	12	MS26574-D3L	4200-007-3	22
MS3320-4VL	4310-024-4	24	MS14154-20VL	4330-009-20	32	MS25361-60	160-012-60	12	MS26574-D4	4200-006-4	22
MS3320-5	4310-001-5	24	MS22073-1	4001-001-1	32	MS25361-60V	160-086-60	12	MS26574-D4L	4200-007-4	22
MS3320-5L	4310-005-5	24	MS22073-1V	4001-008-1	32	MS25361-70	160-012-70	12	MS26574-D5	4200-006-5	22
MS3320-5V	4310-019-5	24	MS22073-1 1/2	4001-001-105	20	MS25361-70V	160-086-70	12	MS26574-D5L	4200-007-5	22
MS3320-5VL	4310-024-5	24	MS22073-1 1/2V	4001-008-105	20	MS25361-75	160-012-75	12	MS26574-D7 1/2	4200-006-705	22
MS3320-7 1/2	4310-001-705	24	MS22073-2	4001-001-2	20	MS25361-75V	160-086-75	12	MS26574-D7 1/2L	4200-007-705	22
MS3320-7 1/2L	4310-005-705	24	MS22073-2V	4001-008-2	20	MS25361-80	160-012-80	12	MS26574-D10	4200-006-10	22
MS3320-7 1/2V	4310-019-705	24	MS22073-2 1/2	4001-001-205	20	MS25361-80V	160-086-80	12	MS26574-D10L	4200-007-10	22
MS3320-7 1/2VL	4310-024-705	24	MS22073-2 1/2V	4001-008-205	20	MS25361-90	160-012-90	12	MS26574-D15	4200-006-15	22
MS3320-10	4310-001-10	24	MS22073-3	4001-001-3	20	MS25361-90V	160-086-90	12	MS26574-D15L	4200-007-15	22
MS3320-10L	4310-005-10	24	MS22073-3V	4001-008-3	20	MS25361-100	160-012-100	12	MS26574-D20	4200-006-20	22
MS3320-10V	4310-019-10	24	MS22073-4	4001-001-4	20	MS25361-100V	160-086-100	12	MS26574-D20L	4200-007-20	22
MS3320-10VL	4310-024-10	24	MS22073-4V	4001-008-4	20	MS26574-3/4	4200-001-075	12			
MS3320-15	4310-001-15	24	MS22073-5	4001-001-5	20	MS26574-3/4A	4200-004-075	12	<b>MIL-C-83383</b>		
MS3320-15L	4310-005-15	24	MS22073-5V	4001-008-5	20	MS26574-3/4L	4200-003-075	22	M83383/01-01	SM600BA5N1	34
MS3320-15V	4310-019-15	24	MS22073-7 1/2	4001-001-705	20	MS26574-1A	4200-004-1	22	M83383/01-03	SM600BA10N1	34
MS3320-15VL	4310-024-15	24	MS22073-7 1/2V	4001-008-705	20	MS26574-1L	4200-003-1	22	M83383/01-04	SM600BA15N1	34
MS3320-20	4310-001-20	24	MS22073-10	4001-001-10	20	MS26574-1 1/2	4200-001-105	22	M83383/01-05	SM600BA20N1	34
MS3320-20L	4310-005-20	24	MS22073-10V	4001-008-10	20	MS26574-1 1/2A	4200-004-105	22	M83383/01-06	SM600BA25N1	34
MS3320-20V	4310-019-20	24	MS22073-15	4001-001-15	20	MS26574-1 1/2L	4200-003-105	22	M83383/01-07	SM600BA35N1	34
MS3320-20VL	4310-024-20	24	MS22073-15V	4001-008-15	20	MS26574-2	4200-001-2	22	M83383/01-08	SM600BA40N1	34
MS14154-1	4330-001-1	32	MS22073-20	4001-001-20	20	MS26574-2A	4200-004-2	22	M83383/01-09	SM600BA50N1	34
MS14154-1L	4330-007-1	32	MS22073-20V	4001-008-20	20	MS26574-2L	4200-003-2	22	M83383/01-10	SM600BA60N1	34
MS14154-1V	4330-008-1	32	MS22073-D1	4001-011-1	20	MS26574-2 1/2	4200-001-205	22	M83383/01-11	SM600BA75N1	34
MS14154-1VL	4330-009-1	32	MS22073-D1 1/2	4001-011-105	20	MS26574-2 1/2A	4200-004-205	22	M83383/01-13	SM600BA100N1	34
MS14154-2	4330-001-2	32	MS22073-D2	4001-011-2	20	MS26574-2 1/2L	4200-003-205	22	M83383/02-01	SM600BA5A1	34
MS14154-2L	4330-007-2	32	MS22073-D2 1/2	4001-011-205	20	MS26574-3	4200-001-3	22	M83383/02-03	SM600BA10A1	34
MS14154-2V	4330-008-2	32	MS22073-D3	4001-011-3	20	MS26574-3A	4200-004-3	22	M83383/02-04	SM600BA15A1	34
MS14154-2VL	4330-009-2	32	MS22073-D4	4001-011-4	20	MS26574-3L	4200-003-3	22	M83383/02-05	SM600BA20A1	34
MS14154-2 1/2	4300-001-205	32	MS22073-D5	4001-011-5	20	MS26574-4	4200-001-4	22	M83383/02-06	SM600BA25A1	34
MS14154-2 1/2L	4330-007-205	32	MS22073-D7 1/2	4001-011-705	20	MS26574-4A	4200-004-4	22	M83383/02-07	SM600BA35A1	34
MS14154-2 1/2V	4330-008-205	32	MS22073-D10	4001-011-10	20	MS26574-4L	4200-003-4	22	M83383/02-08	SM600BA40A1	34
MS14154-2 1/2VL	4330-009-205	32	MS22073-D15	4001-011-15	20	MS26574-5A	4200-004-5	22	M83383/02-09	SM600BA50A1	34
MS14154-3	4330-001-3	32	MS22073-D20	4001-011-20	20	MS26574-5L	4200-003-5	22	M83383/02-10	SM600BA60A1	34
MS14154-3L	4330-007-3	32	MS25244-5	700-001-5	16	MS26574-7 1/2	4200-001-705	22	M83383/02-11	SM600BA75A1	34
MS14154-3V	4330-008-3	32	MS25244-7 1/2	700-001-705	16	MS26574-7 1/2A	4200-004-705	22	M83383/02-13	SM600BA100A1	34
MS14154-3VL	4300-009-3	32	MS25244-10	700-001-10	16	MS26574-7 1/2L	4200-003-705	22	M83383/04-03	SM601BA10A1	34
MS14154-4	4330-001-4	32	MS25244-15	700-001-15	16	MS26574-10	4200-001-10	22	M83383/04-05	SM601BA20A1	34
MS14154-4L	4330-007-4	32	MS25244-20	700-001-20	16				M83383/04-07	SM601BA35A1	34
MS14154-4V	4330-008-4	32	MS25244-25	700-001-25	16				M83383/04-08	SM601BA40A1	34
									M83383/04-10	SM601BA60A1	34