



Heavy-Duty Three-Pole High Performance

Three-phase protection of circuits from 50 to 100 amperes.

Interphase Insulation

Insulating interphase barriers separate adjacent terminals.

Common Trip Bar

One bar connects the three operating mechanisms for simultaneous trip action. Trip bar is removable for installation.

Performance Rated Circuit Breaker

The 940 series is the only three-pole heavy-duty aircraft-type circuit breaker available in the 50 to 100 ampere range and consists of three specially built 160-012 breakers with insulating interphase barriers separating adjacent terminals. The unit has a common trip bar connecting the three operating mechanisms so that an overload tripping one pole will simultaneously trip the remaining two poles.

PERFORMANCE DATA

Interrupting Capacity	1,200A at 120V 400 Hz., AC
Endurance	At 120VAC, 400 Hz.: inductive load — 5,000 cycles; resistive load — 5,000 cycles; mechanical cycling, no load — 5,000 cycles
Overload Cycling	100 cycles minimum at 200% rated current and rated voltage
Dielectric Strength	1,500V, minimum
Insulation Resistance	Not less than 100 megohms at 500V, DC
Voltage Drop	Varies with rating (see "Ordering Information")
Vibration	Exceeds MIL-STD-202, Method 204, Condition A except, 7G peak
Shock	Exceeds 30G's, 11 Millisec (half-sine pulse) MIL-STD-202, Method 213 Test J
Acceleration	Exceeds 10G's
Weight	390 grams (.860 lbs.)

OVERLOAD CALIBRATION DATA

Specification Table	@ 25°C		@ +71°C		@ -40°C		Test Time Parameters
	MIN	MAX	MIN	MAX	MIN	MAX	
Must Hold	105	—	70	—	145	—	% For 1 Hour
Must Trip	—	138	—	115	—	170	% Within 1 Hour
200% Overload	15	70	—	—	—	—	Seconds
400% Overload	2	10	—	—	—	—	Seconds
600% Overload	1	4	—	—	—	—	Seconds

Trip curve available.

ORDERING INFORMATION

Ampere Rating	Voltage Drop Max.*	Part Number
50	0.15	940-006-50
60	0.15	940-006-60
70	0.15	940-006-70
75	0.15	940-006-75
80	0.15	940-006-80
90	0.15	940-006-90
100	0.15	940-006-100

* At rated nominal current.

Data depicted is for the 940 Series. Also available to order are 920, 930, 960, and 970 Series devices. For other amperage ratings and configurations, consult the Business Unit.

DIMENSIONS

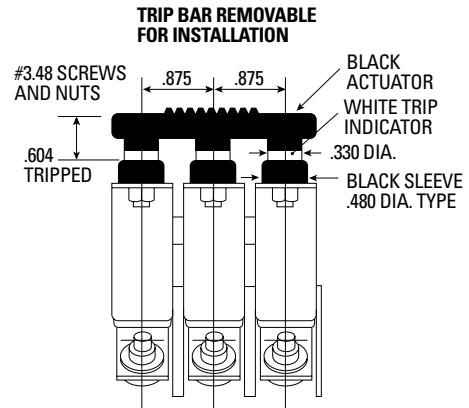
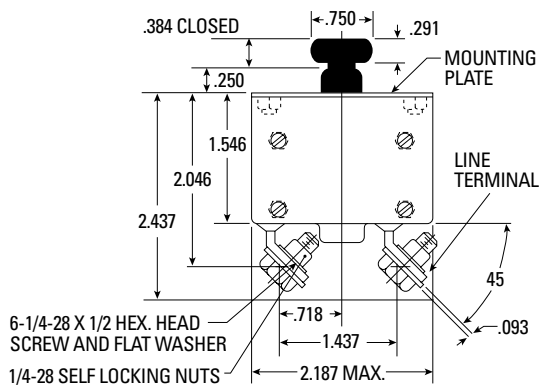
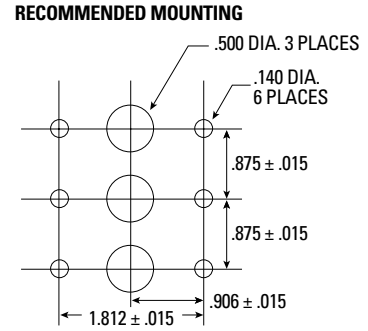
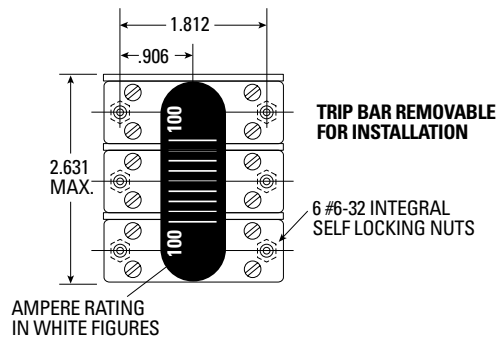

TRIP CURVE

