

# INDUSTRIAL - ENVIRONMENTALLY SEALED SWITCHES

Series - 8520-8522, 8526-8528

Environmentally Sealed Toggle Switches  
UL Recognized and CSA Certified

FEATURES	SPECIFICATIONS	CURRENT RATINGS					
		Amperes		Maximum Horsepower			
<ul style="list-style-type: none"> <li>Completely sealed against dust, moisture, and other contaminants</li> <li>UL and CSA approved</li> <li>One hole mounted bushing for easy installation</li> <li>Multi-circuits offered</li> <li>2 &amp; 3 position with maintained and momentary action</li> <li>Molded-in terminal inserts and terminal numbers</li> <li>1, 2 and 4 pole circuitry</li> </ul>	<ul style="list-style-type: none"> <li>Watertight seal per MIL-STD-108E and designed to meet IP68</li> <li>Thermoset molding materials meet flame retardant requirements</li> <li>UL recognized and CSA certified per specifications listed below</li> <li>Temperature Range: -50°F to +150°F (-46°C to +66°C)</li> <li>Life: 20,000 operations at rated load 40,000 operations mechanical life 6,000 operations at HP ratings per UL and CSA requirements</li> <li>Bushing: 15/32" - 32 thread</li> </ul>			1 Phase		3 Phase	
		125V	250V	125VAC	250VAC	125/250 VAC	
		8520	18	9	1/4	1/2	—
		8521	18	9	1/2	1	—
		8522	18	9	1/2	1	1
		8526 thru 8528	18	9	—	—	—

## SELECTION TABLE

### FLUSH TERMINAL SCREWS



8520/8526



8521/8527



8522/8528

CIRCUIT WITH LEVER IN . . .			ONE POLE	TWO POLE	FOUR POLE
Up Position	Center Position	Down Position (Keyway)	Catalog Number	Catalog Number	Catalog Number
			8520K1	8521K1	8522K1
ON	OFF	ON	K9	K9	K9
ON	NONE	OFF	K4	K4	K4
ON	NONE	ON*	8526K5	8527K5	8528K5
*ON	OFF	ON*	K2	K2	K2
ON	OFF	ON*	8526K3	8527K3	8528K3

**\* Momentary contact.**

See page A71 for circuit diagrams.

UL & CSA Approval Numbers

UL - Where devices are UL recognized, recognition is listed under file number E15346; Guide card number is WOYR2.

CSA = Where devices are CSA certified, certification number is LR40068, class number 6241.

# INDUSTRIAL - ENVIRONMENTALLY SEALED SWITCHES

Series - 8520-8522, 8526-8528

Environmentally Sealed Toggle Switches  
UL Recognized and CSA Certified

## MOUNTING DIMENSIONS - ONE POLE / 8520, 8526

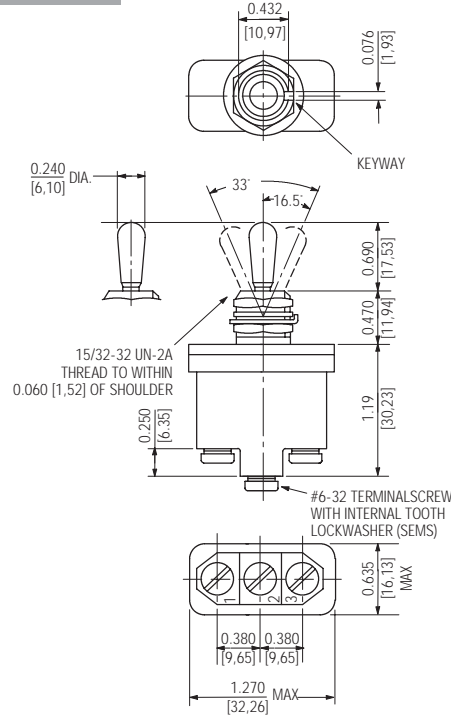

Terminal Identification

## MOUNTING DIMENSIONS - TWO POLE / 8521, 8527

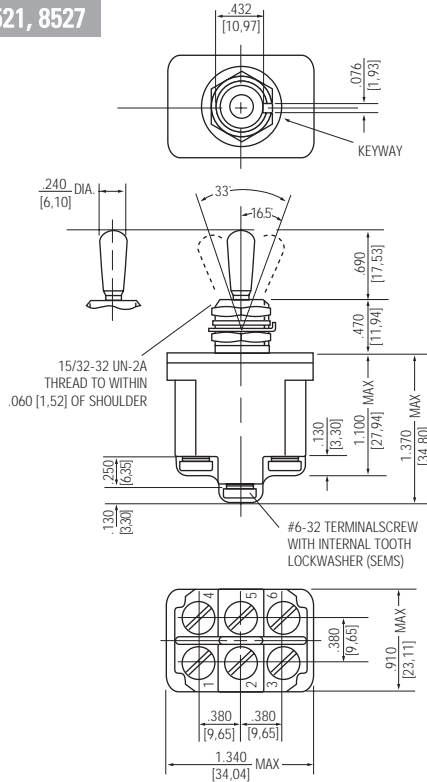

Terminal Identification

**STANDARD**

0.00 = inches

[0,0] = mm

Mounting dimensions for reference only.

Non-functional terminals not supplied.

