

ENGINEERING DATA SHEET

CC0519P

CONTACTOR

1PST-DB+AUX, 500 AMP/28 VDC

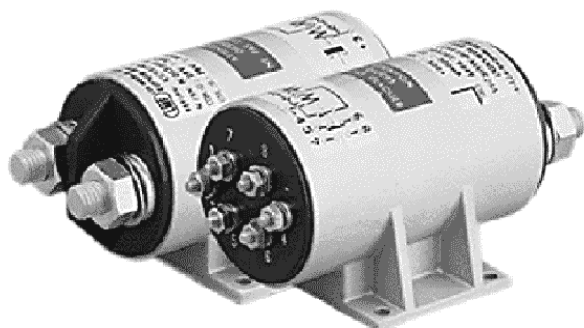

Permanent duty
 Main contact **1PST-NC-DB Form Y**
 Auxiliary contact **1PDT (1NO + 1NC)**
 Coil supply **Direct current**
 - Polarized and protected coil **See schematic diagram**
 Meets the requirements of **AIR 7304 AIR 8456B**
AIR 9456 MIL 6106J

PRINCIPLE TECHNICAL CHARACTERISTICS

Contacts rated at **500 A/ 28 Vdc**
 Weight
 - Ref. P/N: CC0519P-MMR28A **975 g ±10%**
 Maximum size **121mm x 70mm x 62.5mm**
 Dust proof metal can.

CONTACT ELECTRICAL CHARACTERISTICS

Contact rating per pole and load type	Load Current in Amps @28Vdc	
	@28Vdc	@115Vac/400Hz
Resistive	500 (In)	
Inductive	300	
Motor	500	
Overload	8 In [1]	
Rupture	10 In [2]	
I minimum	In/10	
Auxiliary contact rating	@28Vdc	@115Vac/400Hz
Resistive	5	5
Inductive (L/R=5ms)	2.5	2.5
Lamp	2	2

Notes:

- [1] 4000 Amps for 50 cycles; duty cycle: .2 sec on, 20 sec off.
- [2] 5000 Amps for 50 cycles; duty cycle: .2 sec on, 20 sec off.
- 3. Other models available upon request. Contact factory.
- [4] 28A standard. Other units available upon request.



Leach International
www.leachintl.com

North America
 6900 Orangethorpe Ave.
 P.O. Box 5032
 Buena Park, CA 90622 USA

Tel: (01) 714-736-7599
 Fax: (01) 714-670-1145

Europe, SA
 2 Rue Goethe
 57430 Sarralbe
 France

Tel: (33) 3 87 97 98 97
 Fax: (33) 3 87 97 84 04

Asia-Pacific Ltd.
 20/F Shing Hing Commercial Bldg.
 21-27 Wing Kut Street
 Central, Hong Kong

Tel: (852) 2 191 2886
 Fax: (852) 2 389 5803

Data sheets are for initial product selection and comparison. Contact Leach International prior to choosing a component.

COIL CHARACTERISTICS AT 20 °C**SERIES CC0519P**

CODE	R
Nominal operating voltage	28 Vdc
Maximum operating voltage	32 Vdc
Maximum pickup voltage	18 Vdc (18 Vdc)
Drop-out voltage	2 Vdc min. to 8 Vdc max.
Cut-in current	10 A at 28 Vdc
Holding current	300 mA at 28 Vdc
Coil suppression (max Vdc)	- 65

GENERAL CHARACTERISTICS

Temperature range	-55°C to +125°C
Minimum operating cycles (life) at rated load	50,000 cycles
Overload time at 2 x I nominal (2 x 500A)	5 s
Dielectric strength at sea level	500 Vrms
Dielectric strength at altitude 25,000 m	300 Vrms
Insulation resistance at 500 Vdc	100 M Ω
Sinusoidal vibration	10 G / 5 to 2000 Hz
Shock	30 G / 11 ms
Maximum contact opening time under vibration and shock	10 μs
Maximum operate time at 28 Vdc	20 ms
Maximum release time at 28 Vdc	15 ms
Main contact voltage drop	
- Initial value	120 mV
- After endurance test	180 mV
Auxiliary contact voltage drop	
- Initial value	60 mV
- After endurance test	120 mV
Auxiliary contacts	
- Contact resistance (low level)	1 Ω
- I minimum	2 mA
Assembly torque	
- Main contact terminals	14.7 Nm
Coil and auxiliary contact terminals	1.2 Nm

MOUNTING STYLES

SERIES CC0519P

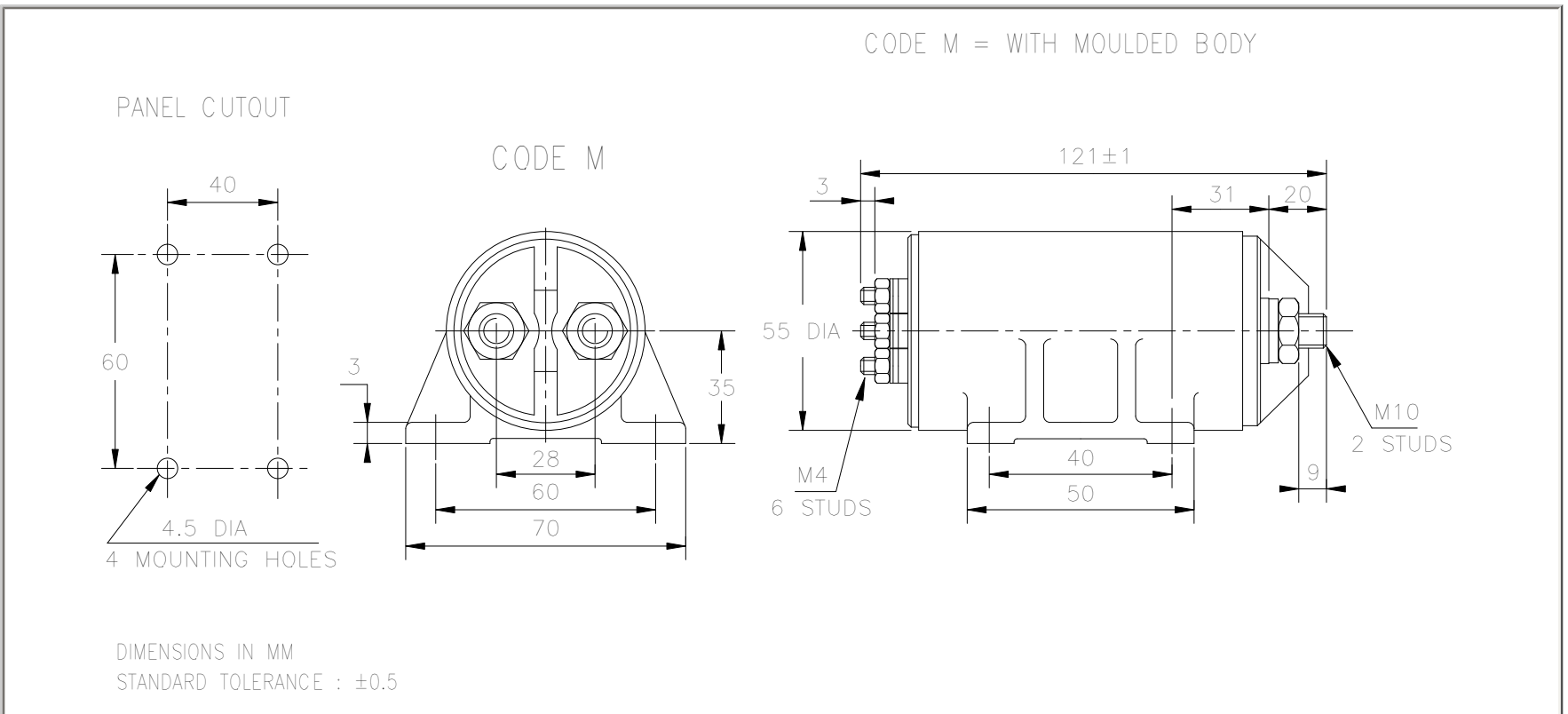

TERMINAL TYPES

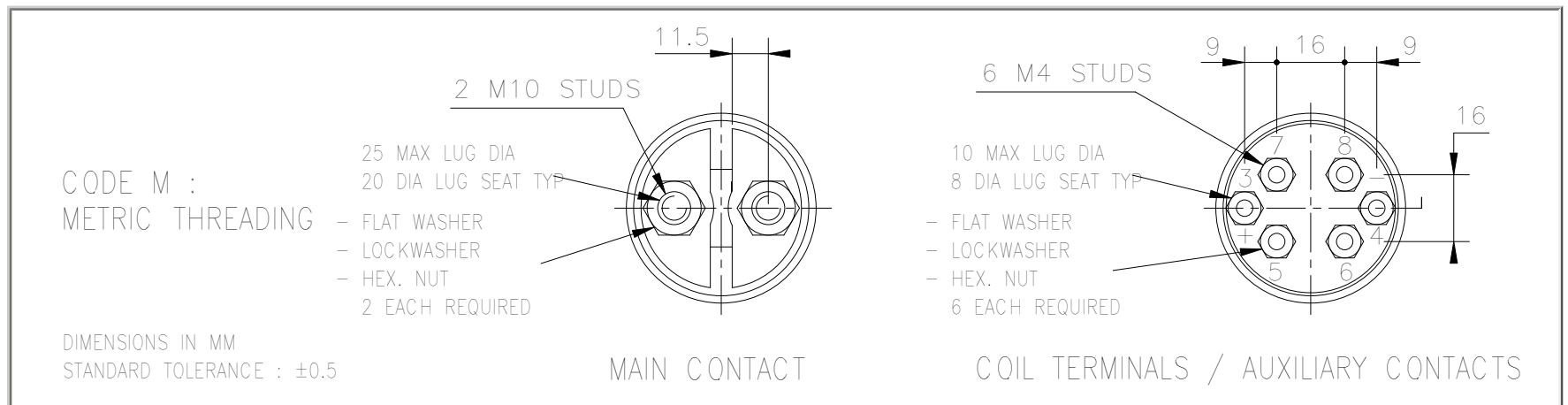

SCHEMATIC DIAGRAM

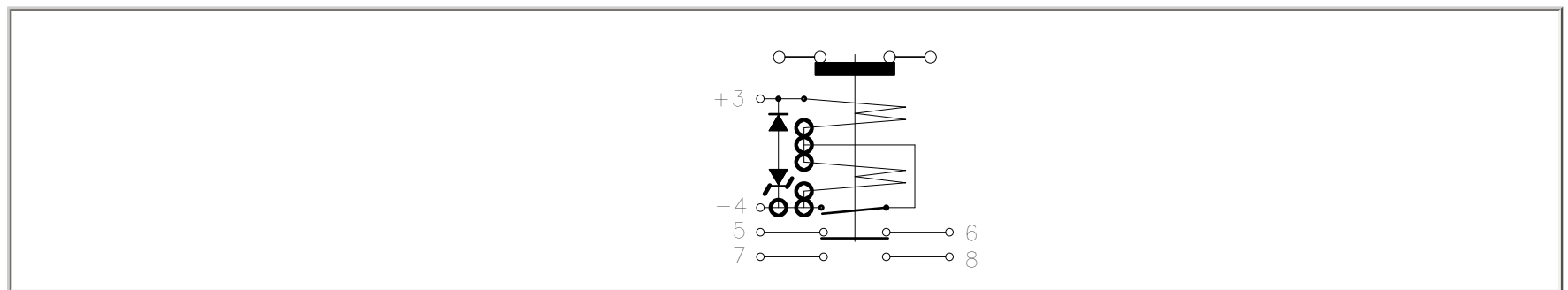

NUMBERING SYSTEM

	CC0519P	-	M	M	R	28A
Basic series designation						
1-Mounting Style (M)						
2-Terminals Style (M)						
3-Coil Voltage Style (R)						
4-Data Sheet Number (28A, xxx) [4]						