

ENGINEERING DATA SHEET

SERIES KXL

RELAY - MAGNETIC LATCH
1 PST/NO(DM), 75 AMP

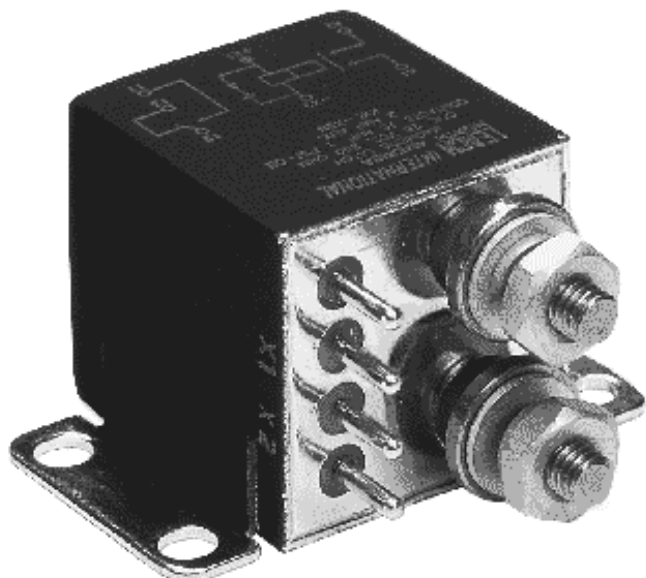

All welded construction

Contact arrangement

1 PST NO-DM Configuration in one inch cube

Meets the standards and requirements of

MIL-PRF-6106

PRINCIPLE TECHNICAL CHARACTERISTICS

Contacts rated at

28 Vdc

Weight

3.0 oz max

Dimensions

1.12in x 1.01in x 1.01in

Hermetically sealed, corrosion resistant metal can.

CONTACT ELECTRICAL CHARACTERISTICS

Contact rating per pole and load type [1]	Load current in Amps
	@28 Vdc
Resistive [2]	75
Inductive [3]	20
Motor [3]	20
Lamp [3]	10
Overload	400



Leach International
www.leachintl.com

North America
6900 Orangethorpe Ave.
P.O. Box 5032
Buena Park, CA 90622 USA

Tel: (01) 714-736-7599
Fax: (01) 714-670-1145

Europe, SA
2 Rue Goethe
57430 Sarralbe
France

Tel: (33) 3 87 97 98 97
Fax: (33) 3 87 97 84 04

Asia-Pacific Ltd.
20/F Shing Hing Commercial Bldg.
21-27 Wing Kut Street
Central, Hong Kong

Tel: (852) 2 191 2886
Fax: (852) 2 389 5803

Data sheets are for initial product selection and comparison. Contact Leach International prior to choosing a component.

COIL CHARACTERISTICS (Vdc)**SERIES KXL**

CODE	A	B	C	M	N [6]	R [6]	V [6]
Nominal operating voltage	28	12	6	48	28	12	6
Maximum operating voltage	29	14.5	7.3	50	29	14.5	7.3
Maximum pickup voltage							
- Cold coil at +125° C	18	9	4.5	36	18	9	4.5
- During high temp test at +125° C	19.8	9.9	5	38	19.8	9.9	5
- During continuous current test at +125° C	22.5	11.25	5.7	42	22.5	11.25	5.7
Coil resistance Ω $\pm 10\%$ +25° C except type "C" & "V" +20%, -10%	450	112	28	1500	450	112	28

GENERAL CHARACTERISTICS

Temperature range	-70°C to +125°C
Minimum operating cycles (life) at rated load	20,000 [3]
Minimum operating cycles (life) at 25% rated load	200,000
Dielectric strength at sea level	
- All circuits to ground and circuit to circuit	1250 Vrms
- Coil to ground	1000 Vrms
Dielectric strength at altitude 80,000 ft	500 Vrms [4]
Insulation resistance	
- Initial (500 Vdc)	100 M Ω min
- After environmental tests (500 Vdc)	50 M Ω min
Sinusoidal vibration	0.12" DA / 10 to 57 Hz 20G / 57 to 2000 Hz
Random vibration	
- Applicable specification	MIL-STD-202
- Method	214
- Test condition	1E (0.2G ² /Hz, 50 to 2000 Hz)
- Duration	15 minutes each plane
Shock	50G / 11 ms \pm 1ms
Maximum contact opening time under vibration and shock	10 μ s
Operate time at nominal voltage @25°C	15 ms max
Release time at nominal voltage @25°C	15 ms max
Contact make bounce at nominal voltage @25°C	1 ms max (auxiliary contacts, 4 ms max)
Contact release break bounce at nominal voltage @25°C	0.5 ms max [7]
Weight maximum	3.0 oz

Unless otherwise noted, the specified temperature range applies to all relay characteristics.

NOTES

SERIES KXL

- [1] Standard Intermediate current test applicable.
- [2] For full rated load max. temp. and altitude use No. 6 wire or larger.
Relays to be mounted to limit mounting bracket temp. to 160 °C.
- [3] DC inductive load 10,000 cycles. Motor load 20,000 cycles, lamp load 10,000 cycles.
- [4] Applicable military specification: MIL-PRF-6106.
- 5. Special models available: i.e. high reliability testing, suppressed coil, etc.
- [6] "N R & V" coils have back EMF suppression to - 42 volts maximum.
- [7] Applies to "N, R & V" coils only.
- 8. Relay will not operate, but will not be damaged by application of reverse polarity to coil.

NUMBERING SYSTEM

	KXL	-	X	9	A
Basic series designation _____					
1-Mounting Style (Contact factory) _____					
2-Terminal Types (9) _____					
3-Coil Voltage see coil characteristics (A,B,C,M,N,R or V) _____					

MOUNTING STYLES

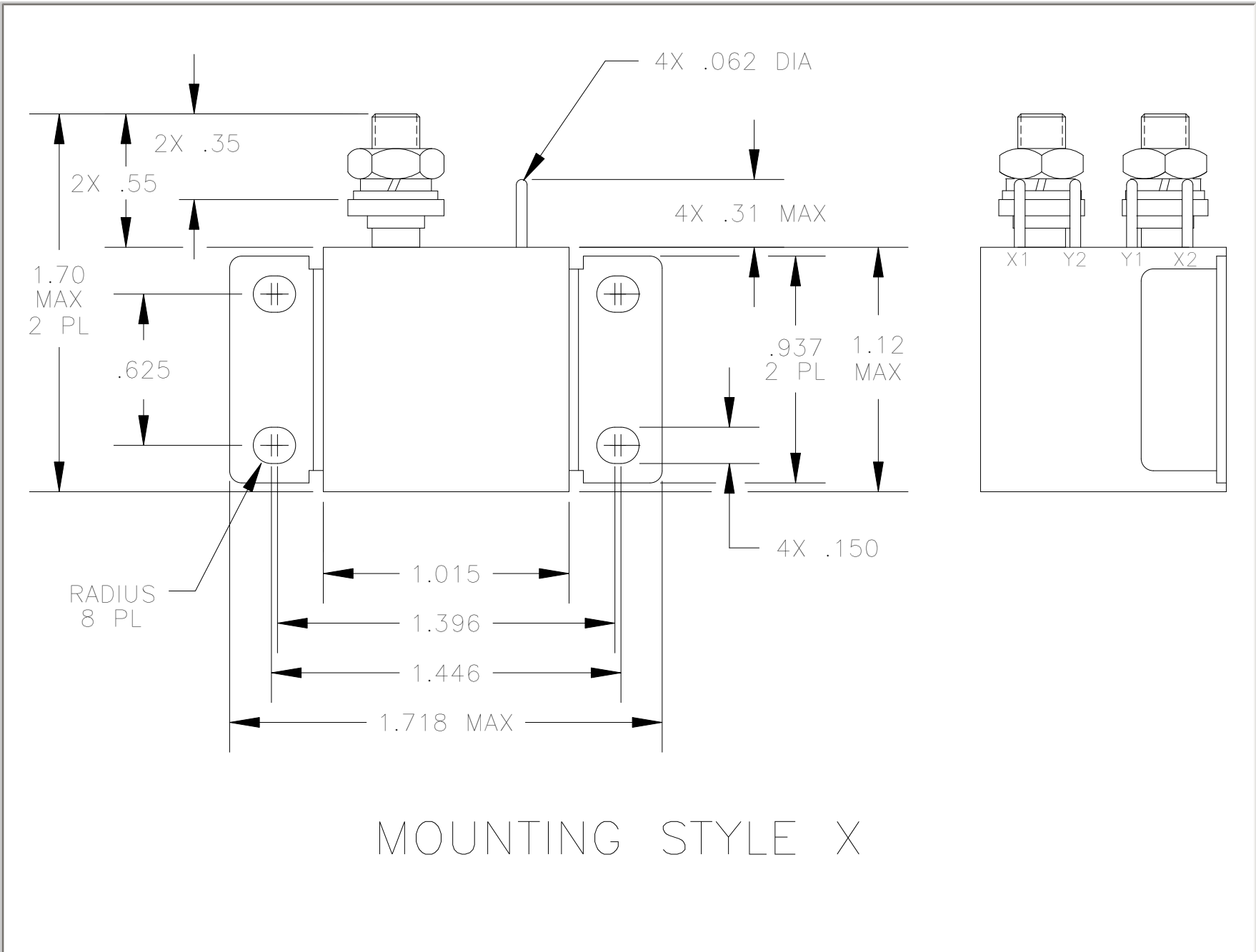

Standard Tolerance: .xx ± .03, .xxx ± .010

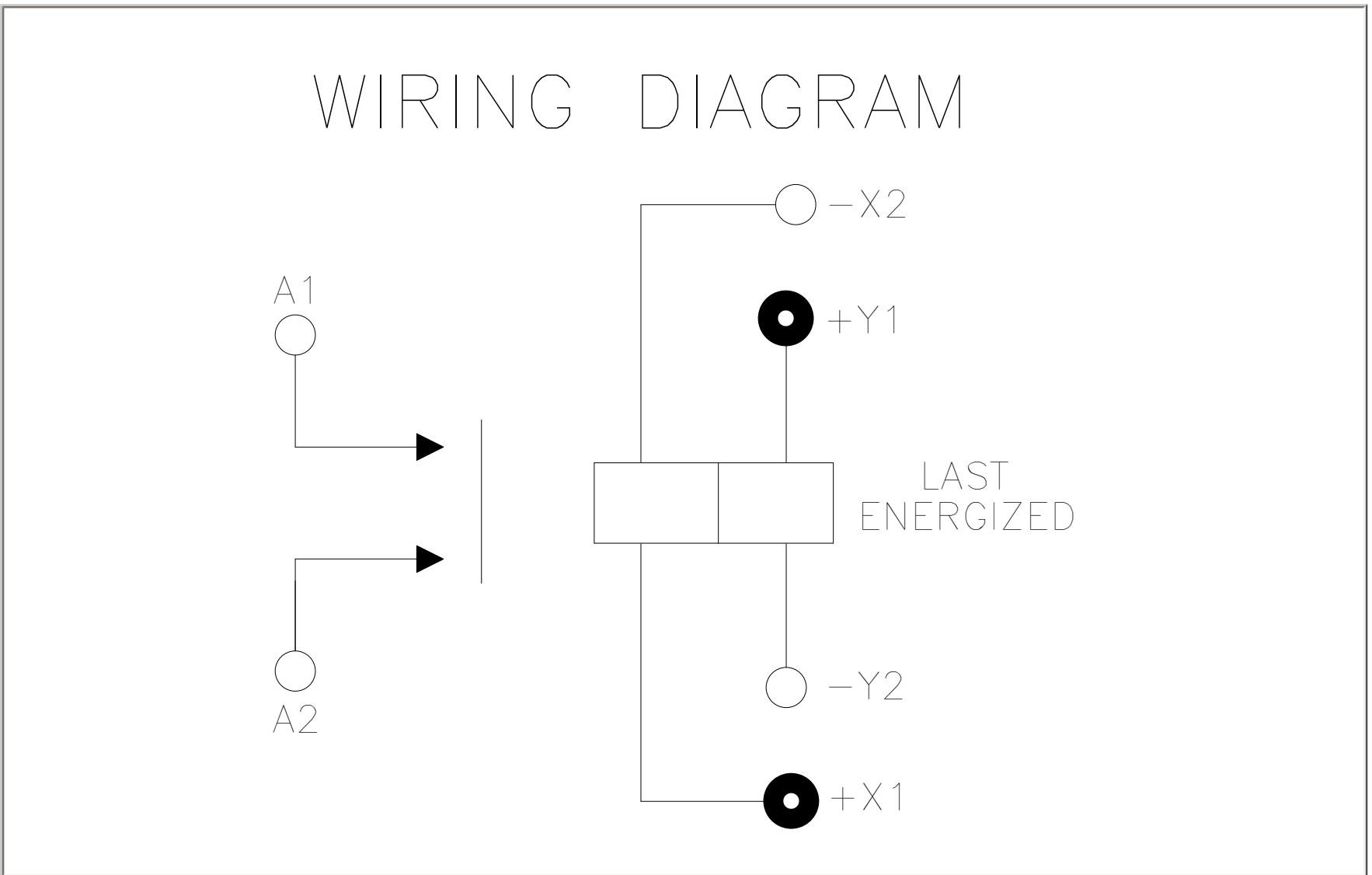
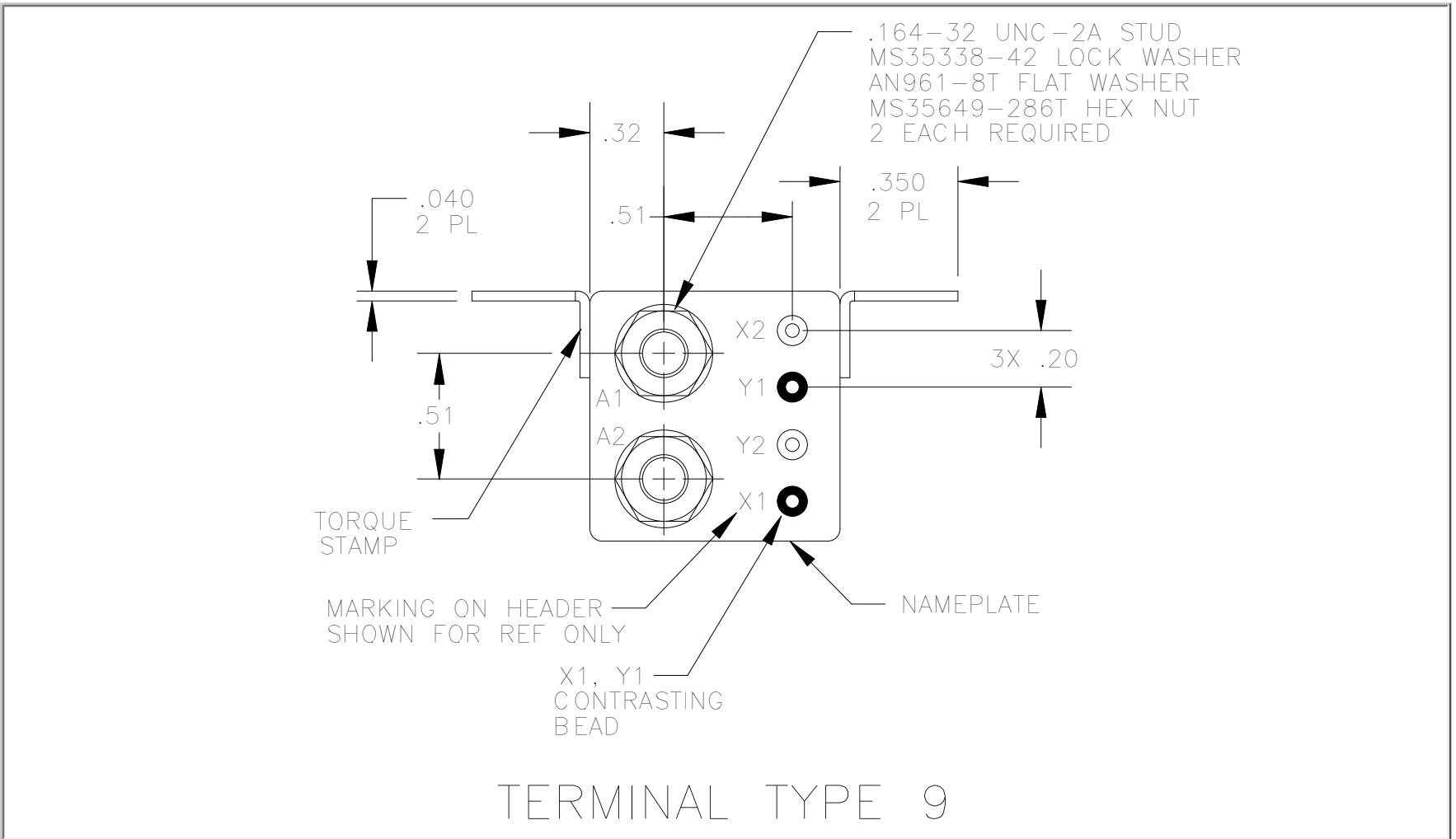

STANDARD TOLERANCE: .xx ±.03; .xxx±.010