



APPLICATION NOTE:

[101](#)

APPLICABLE SOCKETS:

[SM-1000-003](#)

FEATURES

- Small size and weight
- High-reliability design
- Hermetically sealed
- High transient immunity
- Qualified to MIL-PRF-83726/25
- Compatible with M12883/52 & /53 socket module and track mount

PRINCIPLE TECHNICAL CHARACTERISTICS

Enclosure: Hermetic Sealed per MIL-STD-883, Method 1014 Condition B,C	Yes
Finish: per MIL-T-10727	Tin Plate
Terminals: Gold Plate per MIL-G-45204 Type II, Class 2, Grade C	Plug-in
Weight	0.56 Ounce max.

DESCRIPTION

The TDH-1610 Time Delay Relays have been designed with thick film hybrid microelectronics timing circuits and are packaged in a hermetically sealed military style enclosure. The TDH-1610 series are qualified to MIL-PRF-83726/25 and designed to withstand severe environmental conditions encountered in military/aerospace applications. These relays are suited for use in power control, communication circuits and many other applications where power switching and high reliability are required over a wide temperature range.



Leach International
www.leachintl.com

North America
6900 Orangethorpe Ave.
P.O. Box 5032
Buena Park, CA 90622 USA

Tel: (01) 714-736-7599
Fax: (01) 714-670-1145

Europe, SA
2 Rue Goethe
57430 Sarralbe
France

Tel: (33) 3 87 97 98 97
Fax: (33) 3 87 97 84 04

Asia-Pacific Ltd.
20/F Shing Hing Commercial Bldg.
21-27 Wing Kut Street
Central, Hong Kong

Tel: (852) 2 191 2886
Fax: (852) 2 389 5803

Data sheets are for initial product selection and comparison. Contact Leach International prior to choosing a component.

Input (Control) Parameters	
Timing: a. Operation, Time Delay on b. Method c. Range d. Accuracy	Release Fixed Period 0.05 to 500 Seconds ±10% [1]
Recycle Time	10 ms, min [5]
Operations: (X1-X2) a. Input & Control Voltage b. Operating Current	20-30 Vdc 10 mA, Max @ +25° C
Transients: MIL-STD-704A, Limit 1 a. Spike Susceptibility b. Positive, Transients c. Self-Generated Spikes	+80 Volts Max ±600 Volts Max None
Electromagnetic Interference Per MIL-STD-461A	Class 1D [3]
Power Loss	1 ms [2]
Output (Load) Parameters	
Contact Form Contact Rating Voltage Drop, Maximum Leakage Current, Maximum: a. at 28 Vdc and 25° C d. at 28 Vdc and 125° C	SPST 150 mA 2 Vdc 1 Microampere 10 Microamperes
Dielectric Strength: a. @ Sea Level, 60 Hz b. @ 80,000 ft., 60 Hz	1000 Vrms [4] 350 Vrms
Insulation Resistance @ 500 Vdc	1000 M Ω [4]

GENERAL CHARACTERISTICS

Ambient Temperatures Range: a. Operating b. Non-Operating	-55 to +125° C -55 to +125° C
Vibration: a. Sinusoidal	
10-55 Hz	0.06" DA
55-500 Hz	10 G
500-3000 Hz	20 G
b. Random: MIL-STD-810	0.2 G ² /Hz
Shock, 0.5 MS, 1/2 Sine, 3 Axis	1,100 G
Acceleration, in any Axis	100 G
Life at Rated Resistive Load; Minimum	1,000,000 operations

NUMBERING SYSTEM

<u>TDH-1610</u>	-	<u>1001</u>	<u>W</u>	<u>M83726/24</u>	-	<u>1001</u>	<u>W</u>
1		3	4	1	2	3	4
<p>1. Model Number or Basic "MIL-PRF" Series number. 2. Military "Slash" number. 3. Timing Range, Fixed: 100 milliseconds to 500 seconds. (See Note 6). 4. Quality level (See Note 7).</p>							

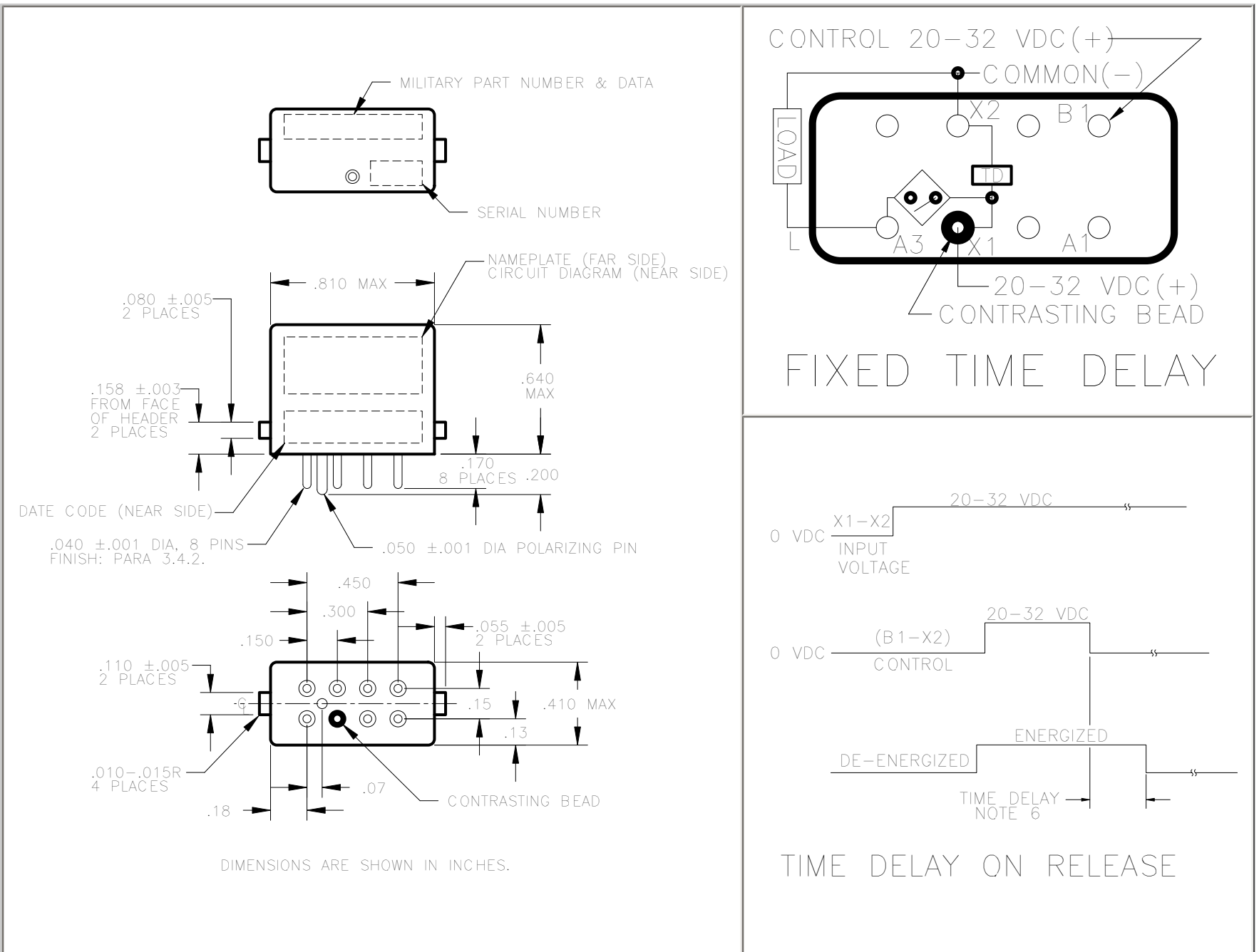

NOTES

- [1] The accuracy specification applies for any combination of operating temperature and voltage.
- [2] The accuracy will not be affected by power interruptions up to 1 millisecond, spaced at least 10 milliseconds apart. Transient and power loss specifications are based on a maximum duty cycle of 1/50.
- [3] EMI test limits will not be exceeded during the timing interval or when continuously energized under steady state conditions, per paragraph 3.23, MIL-PRF-83726C.
- [4] Terminals X1, X2, A1, B1 and A3 must be connected together during the test. Dielectric withstanding voltage and insulation resistance are measured at sea level between all mutually insulated terminals and between all terminals and case.
- [5] Recycle time is defined as the minimum time control power must be removed from terminal B1 to assure that a new cycle can be completed within the specified timing tolerance.
- [6] A four digit number defines the time delay in seconds (or milliseconds). The first three digits are significant figures, used to define the specific time delay. The fourth digit represents the number of zeros to follow the first three digits.
Examples:
- 1001 = 1 second (1,000 milliseconds)
- 2502 = 25 seconds (25,000 milliseconds)
- 5000 = 0.5 seconds (500 milliseconds)
- [7] Quality level as specified in MIL-R-83726, paragraph 3.1.1, 3.1.2 and 3.1.3.

DERATING OF CONTACTS FOR DC VOLTAGES ABOVE NOMINAL RATING

To establish a standard for the derating of relay contacts is, at best, a subjective practice. Limitations are governed by the type of relay, contact gap, maximum voltage capabilities of the relay contact system, and the contact material.

The most common method is to derate the contacts by use of the Power Formula, using the known current and voltage.

This method is valid only for **Resistive Loads**, and is an approximation only; keeping in mind the limitations mentioned above.

$$\text{Power} = IE \text{ (Current x Voltage)}$$

$$I_2 E_2 = 2/3 I_1 E_1$$

Example:

A designer is working with a 55 volt DC system and has a relay rated at 10 amps resistive at 28 volts DC. What is the maximum current that can be switched at 55 Vdc.

$$I_1 = 10 \text{ Amperes}$$

$$E_1 = 28 \text{ VDC}$$

$$E_2 = 55 \text{ VDC}$$

$$I_2 = ? \text{ (Current ratings at 55 VDC Resistive)}$$

$$I_2 E_2 = 2 I_1 E_1 / 3$$

$$I_2 = 2 I_1 E_1 / E_2 \times 3$$

$$= 2 (10 \times 28) / 55 \times 3$$

$$= 560 / 165$$

$$I_2 = 3.4 \text{ Amperes at 55VDC}$$

In addition, the user should always be concerned about the following:

1. Derating contacts that are rated for less than 10 Amperes at nominal voltage.
2. Derating contacts for use in system voltages above 130 Volts DC



APPLICABLE TRACK:
[MT-3000-03](#)

BASIC SOCKET SERIES DESIGNATION FOR:

Series X (Track Mount)
Series TD-1609, TD-1610 (Track Mount)

DESIGNED TO THE STANDARDS AND REQUIREMENTS OF:

MIL-S-12883/52

SOCKET TRACK DRAWING

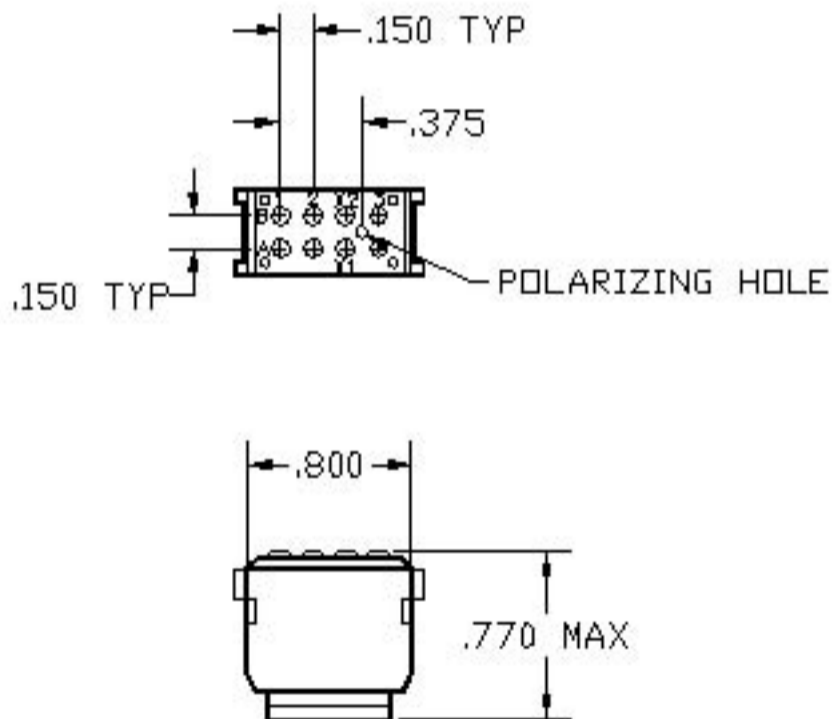

GENERAL CHARACTERISTICS

1. Supplied with No. 20 contacts and No. 20 crimp.

2. Standard tolerances

.xx ±.01; xxx ±.005.

3. Weight

.016 lb. max.

4. Used in conjunction with MT-3000-003



Leach International
www.leachintl.com

North America
6900 Orangethorpe Ave.
P.O. Box 5032
Buena Park, CA 90622 USA

Tel: (01) 714-736-7599
Fax: (01) 714-670-1145

Europe, SA
2 Rue Goethe
57430 Sarralbe
France

Tel: (33) 3 87 97 98 97
Fax: (33) 3 87 97 84 04

Asia-Pacific Ltd.
20/F Shing Hing Commercial Bldg.
21-27 Wing Kut Street
Central, Hong Kong

Tel: (852) 2 191 2886
Fax: (852) 2 389 5803

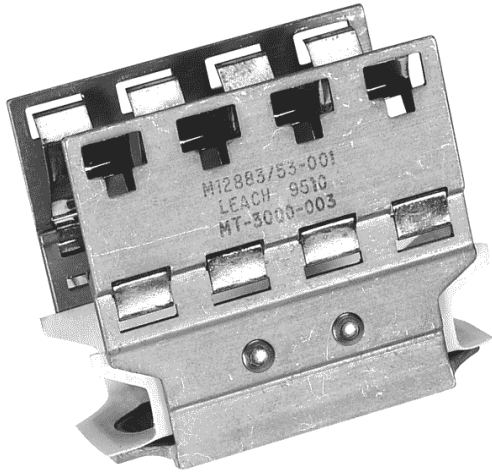

BASIC SOCKET SERIES DESIGNATION FOR:

Series SM Sockets (Track Mount)

DESIGNED TO THE STANDARDS AND REQUIREMENTS OF:

MIL-S-12883/53

SOCKET TRACK DRAWING

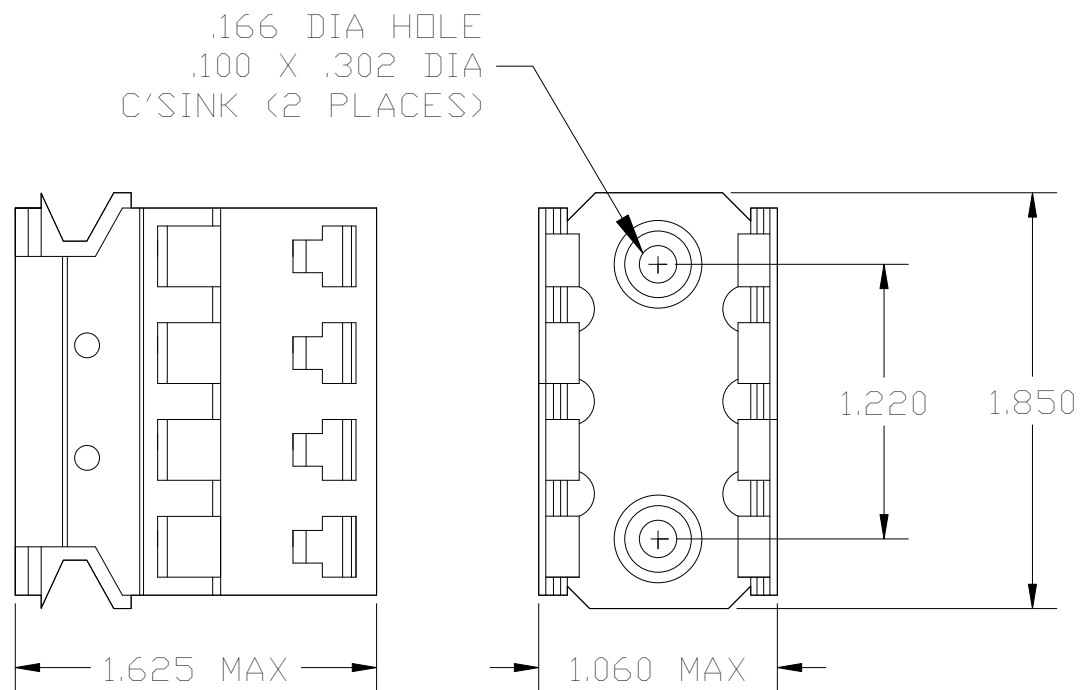

GENERAL CHARACTERISTICS

Used in conjunction with SM-1000-003, SM-1001-003 and SM-1002-003 track mount relay sockets.

Standard tolerances .xx ±.01; xxx ±.005.

Weight .056 lb. max.



Leach International
www.leachintl.com

North America
6900 Orangethorpe Ave.
P.O. Box 5032
Buena Park, CA 90622 USA

Tel: (01) 714-736-7599
Fax: (01) 714-670-1145

Europe, SA
2 Rue Goethe
57430 Sarralbe
France

Tel: (33) 3 87 97 98 97
Fax: (33) 3 87 97 84 04

Asia-Pacific Ltd.
20/F Shing Hing Commercial Bldg.
21-27 Wing Kut Street
Central, Hong Kong

Tel: (852) 2 191 2886
Fax: (852) 2 389 5803

Data sheets are for initial product selection and comparison. Contact Leach International prior to choosing a component.