

KLIXON[®]

20TC Series Circuit Breakers

Rocker Actuated Switch Type

Features

- **Versatile rocker actuator – snap-on, switch type in various styles and colors for panel mounting**
- **Provides dual function – “ON/OFF” circuit switching and protection**



20TC2

Overview

The Klixon 20TC series circuit breaker offers the advantages of integrating an on/off switch and a circuit protector in a trim, compact package. The snap-on actuators are available on request in a variety of colors, styles and indication markings. They are designed to provide a stylish console appearance to the panels of light aircraft, pleasure boats,

home appliances, office reproducing and calculating machines, and data processing equipment.

Several different types of actuators are available. The translucent actuator permits quick identification of the actuator position under low ambient lighting conditions by emitting a soft glow from a light source, such as an edge lighted panel. Colored

actuators will be hot letter stamped in white. White and translucent actuators will be stamped in black.

The growing demand for a highly stylized and aesthetic panel appearance has generated the need for the 20TC. The basic mechanism has been proven for reliability in a wide variety of applications.

Envelope Drawings

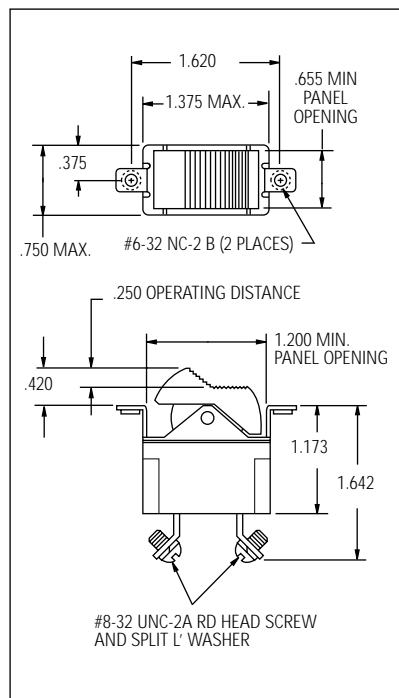

Rocker Button Options (SR12507-156-X)

- 1 PUSH ON / LNDG LITE
- 2 PUSH ON / NAV LITE
- 3 PUSH ON / ANTI COLL
- 4 PUSH ON / PITOT HEAT
- 5 PUSH ON / BOOST PUMP
- 6 PUSH ON / GLIDE SLOPE
- 7 PUSH ON MKR BCN
- 8 PUSH ON / STROBE LITE
- 9 OFF
- 10 OFF
- 11 "SR TO INVERT MARKING"
- 13 PUSH ON / ROT BCN
- 16 PUSH ON / ELEV TRIM
- 18 PUSH ON / RADIO MASTER
- 19 PUSH ON / LDG LITE
- 20 ON / OFF
- 21 OFF
- 22 "COLORED BOX"
- 23 OFF
- 25 ON / OFF
- 26 OFF / ON
- 27 PUSH ON / LOW BOOST
- 28 PUSH ON / HIGH BOOST
- 29 PUSH ON / WX RADAR
- 30 PUSH ON / PROP DE ICE
- 33 PUSH ON / STBY VAC
- 34 NO ACTUATOR
- 35 ON / OFF

Code System

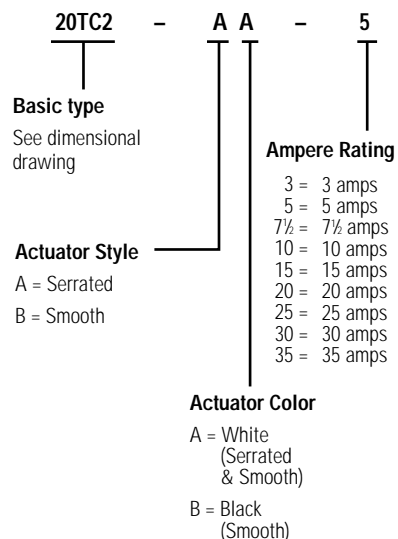

Note: Performance Characteristics similar to 7270/7271 devices on page 22 and 23.

4

3

2

1

REVISIONS						
ZONE	LTR	20TC	DESCRIPTION	PROJ. 1157	DATE	APPROVED
	H		ADDED MAX. OPERATING FORCES NOTE. ECN0028165 PAF		3/22/06	RG

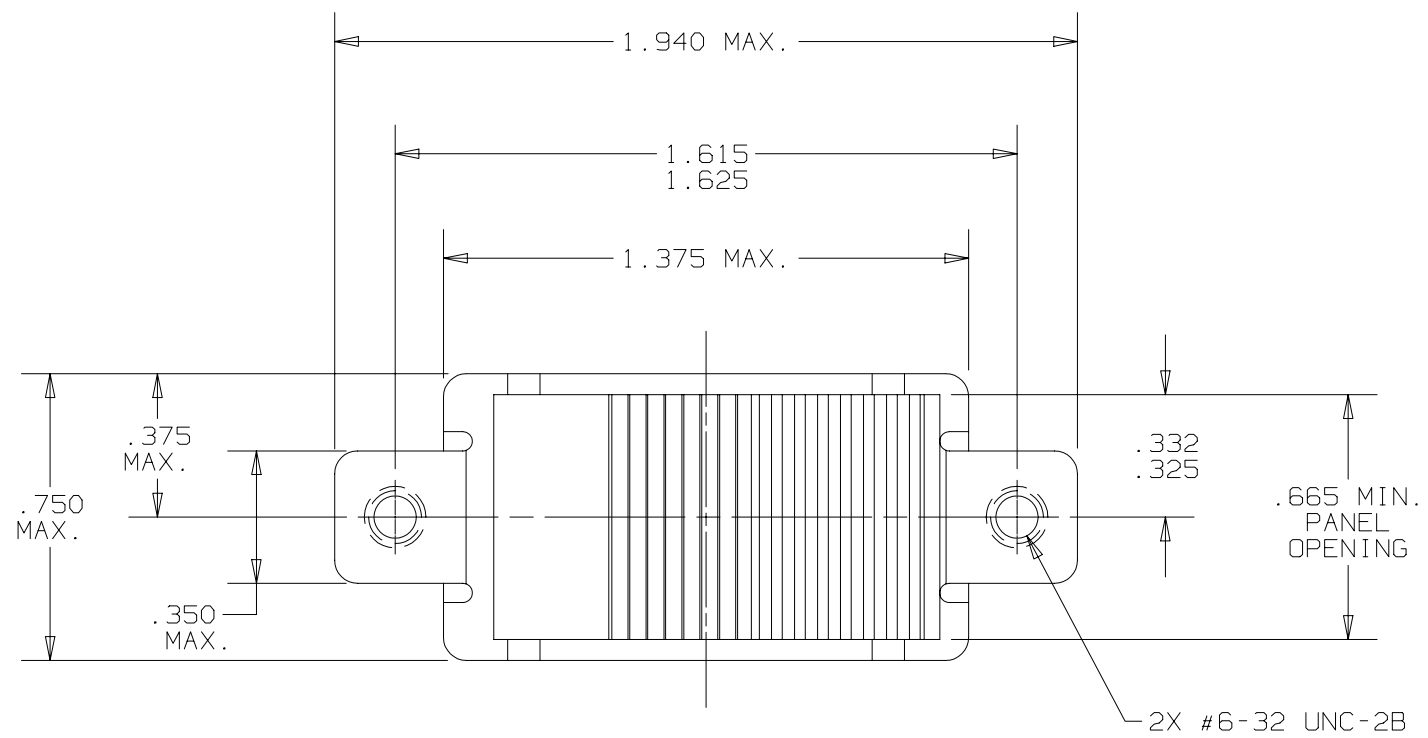

(DETAIL PERFORMANCE PER MIL-C-5809)

OVERLOAD CYCLING-----100 CYCLES AT 200% RATING
 VIBRATION-----10 G'S MINIMUM 50-500 CPS
 MECHANICAL SHOCK-----25 G'S 11.5 MILLISECONDS DURATION
 ACCELERATION-----10 G'S MINIMUM
 CORROSION-----SALT SPRAY 50 HOURS
 HUMIDITY-----10 DAYS
 EXPLOSION PROOF-----WHILE INTERRUPTING RUPTURE CURRENT
 OPERATING ALTITUDE:-----70,000 FT.

VOLTAGE DROP-----3 AMP RATING .75 VOLTS
 5 AMP RATING .65 VOLTS
 7 1/2 AMP-35 AMP RATING .50 VOLTS

ENDURANCE:
 120 VAC-----60-400 CPS, INDUCTIVE -----5000 CYCLES
 RESISTIVE -----5000 CYCLES
 30 VDC-----INDUCTIVE -----2500 CYCLES
 RESISTIVE -----5000 CYCLES
 MECHANICAL-----10000 CYCLES

CALIBRATION:	TEST	CIRCUIT BKR RATING	PERCENT RATED CURRENT	AMB. TEMP.	TRIP TIME
	MIN. ULT. TRIP	3-35	110	25°C	HOLD
	MAX. ULT. TRIP	3-35	150	25°C	1 HR. MAX.
	200% TIME	3-35	200	25°C	10-130 SEC.

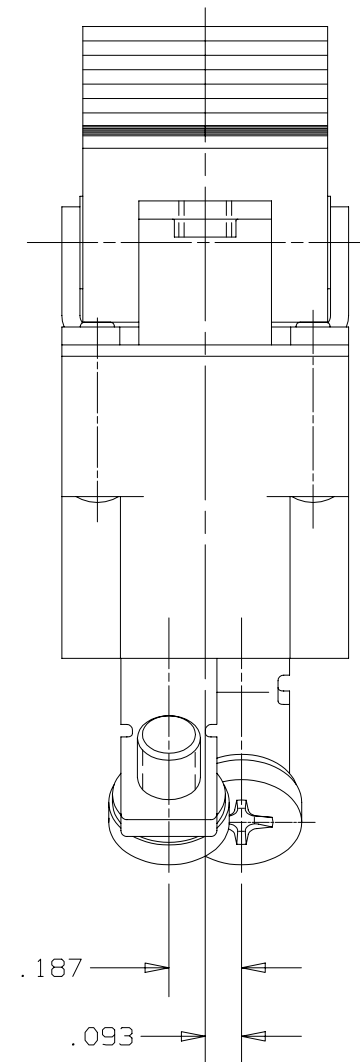
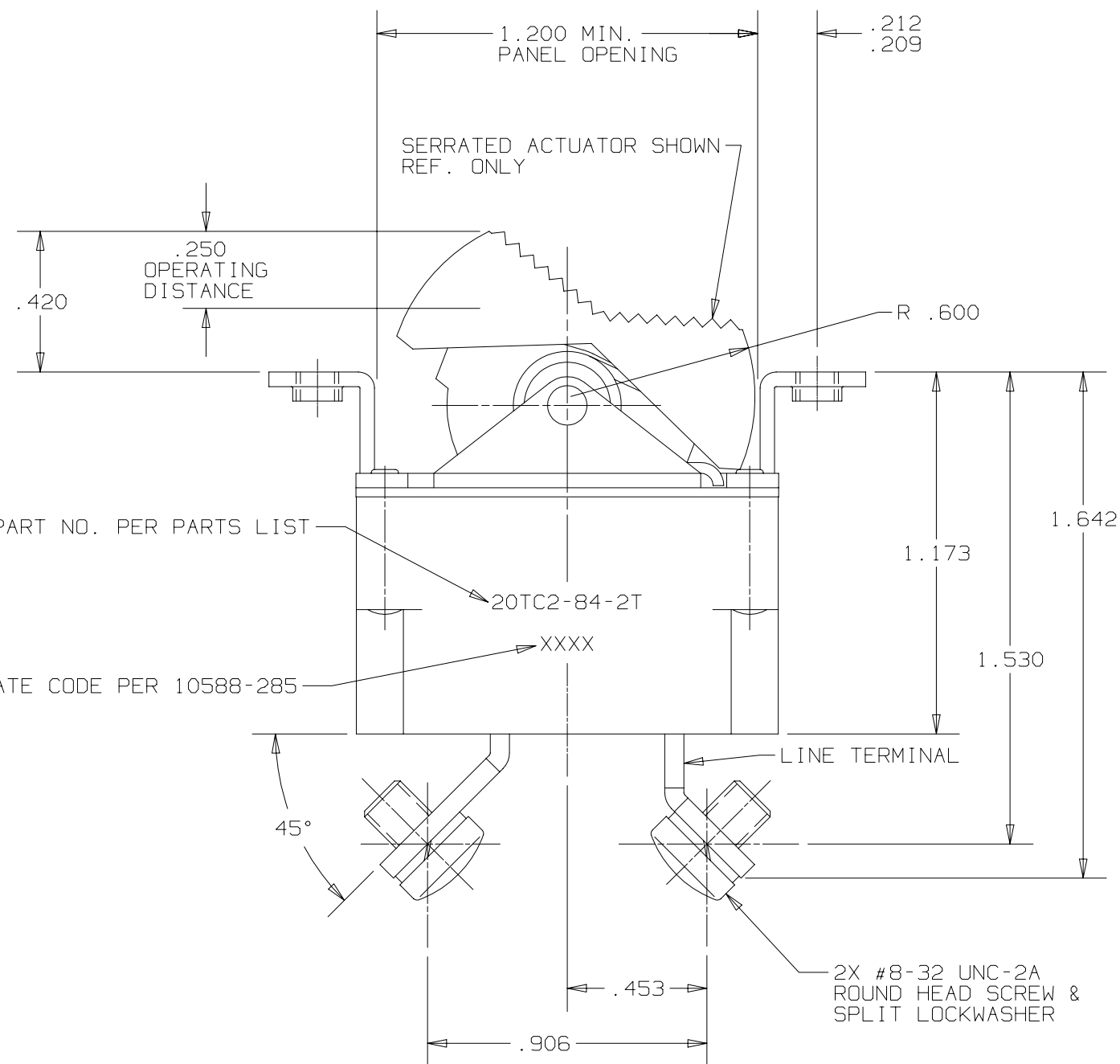

RUPTURE:
 3 AMP THRU 35 AMP
 120 VAC, 400 C'S, 1000-AMPS
 30 VDC, 2000 AMPS

MAXIMUM OPERATING FORCES:
 "ON" POSITION.....10 LBS. MAX.
 "OFF" POSITION.....10 LBS. MAX.



PART NO.	AMP RATING
20TC2- 3	3
20TC2- 5	5
20TC2- 7 1/2	7 1/2
20TC2- 10	10
20TC2- 15	15
20TC2- 20	20
20TC2- 25	25
20TC2- 30	30
20TC2- 35	35

THIS IS A CAD DRAWING. THE GEOMETRY IN THE ASSOCIATED CAD COMPUTER FILE IS DIMENSIONALLY ACCURATE. WHEN DRAWING IS BEING REVISED, THE GEOMETRY MUST BE UPDATED IN ALL VIEWS AND ON ALL SHEETS.

UNLESS OTHERWISE SPECIFIED DIMENSIONS ARE IN INCHES		DRAWN J. HORAN	DATE 8/5/66	03 P18	
TOLERANCE ON FRACTIONS DECIMALS ANGLES		ENGINEER		 	
MATERIAL		APPROVED B. FOLEY	8/26/66	TITLE ROCKER ACTUATED CIRCUIT BREAKER ENVELOPE DRAWING	
		SIGNATURES ON FILE. REFER TO ELECTRONIC CHANGE NOTICE.		SIZE C	CODE IDENT NO. 82647
				20TC2	
		SCALE: 4X		SHEET 1 OF 1	