



2TC49 Series

"Dual Safety™" Circuit Breakers

Features

- **Extension of 2TC series**
- **Redundant protection in hard fault catastrophic conditions**
- **Separable link feature**
- **Case color distinguishes 2TC49 from 2TC series**
- **Uses less space and weighs less than other circuit breaker packages**
- **Rating 2½ - 15 amps**



2TC49
"Dual Safety" Circuit Breaker

Overview

The 2TC49 "Dual Safety™" circuit breaker represents a refinement in electrical control and circuit protection. The 2TC dual safety circuit breaker incorporates a fusible element in a standard 2TC (MS 3320) package size to provide redundant protection in hard fault conditions.

"Hard Fault" Tripping

The 2TC dual safety circuit breaker operates identically to a standard circuit breaker under all normal conditions, including

short circuit. In the event of circumstances which disable the internal circuit breaker mechanisms, such that the device is able to carry current but unable to clear an overload via its normal means, the dual safety element acts as a built in fuse to provide redundant circuit protection.

The key part in the dual safety design is a two part current carrying element joined by a special alloy. The geometry and material of the element determine its heating properties. The

elements heating properties are slower than the bimetal sensor but faster than the smoke curve of the wire the rating is designed to protect. In the case where the standard mechanism is disabled or cannot operate normally, the separable element "fuses" open, interrupting the current.

The benefits of the dual safety design result in calibrated overcurrent protection (based on fuse times) and specified post fuse dielectric properties for system and human protection.

Characteristics

"Dual Safety™" 2TC49

2TC49

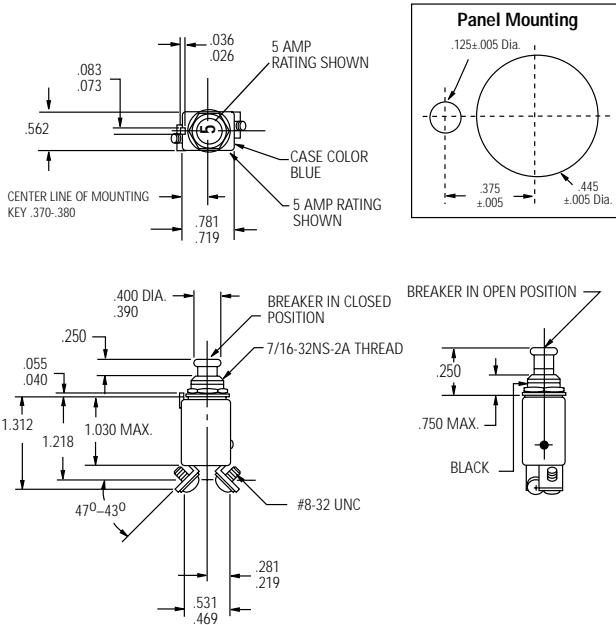

Link Separation Characteristics

Maximum circuit breaker link separation times for locked contact condition as a function of overload

Amp Rating	% Overload Rated Current						
	400%	500%	600%	700%	800%	900%	1000%
2½	-	-	34.0	20.0	13.0	9.0	6.0
3	-	-	34.0	20.0	13.0	9.0	6.0
5	-	95.0	36.0	18.0	10.0	6.0	3.5
7½	69.0	28.0	14.0	8.0	4.0	3.5	2.0
10	60.0	35.0	20.0	12.0	7.0	4.0	2.5

Time (seconds)

Calibration: 2½-15 amps

Temp °C	Min ULT Trip	Max ULT Trip	Trip Time - Seconds		
			200%	500%	1000%
+25	115%	138%	5-20	.5-2.0	.12-.53
-54	115%	165%	7-40	.6-3.0	.16-.8
+121	90%	138%	3-13	.33-1.1	.07-.3

Vibration* 10 G's minimum, 50-50 Hz
 Mechanical Shock 50 G's
 Acceleration 10 G's
 Weight 2TC49 - 25 gm max.

Post-short circuit dielectric 1125 VAC Min (1mA)
 Post-link separation dielectric 900 VAC (1mA)

Interrupt Current

2½ - 15 amps: 6000 amps at 28 VDC
 2½ amps: 2800 amps at 120 VAC, 400 Hz
 3 - 15 amps: 2500 amps at 120 VAC, 400 Hz

Endurance

2500 cycles 120 VAC, 400 Hz Inductive
 5000 cycles 120 VAC, 400 Hz Resistive
 2500 cycles 30 VDC, Inductive
 5000 cycles 30 VDC, Resistive
 10,000 cycles Mechanical, no load

* Other vibration levels available. Contact factory for details.

TI Number	Voltage Drop (max.)**
2TC49-2½	0.70
2TC49-3	0.55
2TC49-5	0.35
2TC49-7½	0.30
2TC49-10	0.28

** Max. voltage drop at nominal rated current

Approximate Time-Current Curves - 2TC49 Circuit Breakers

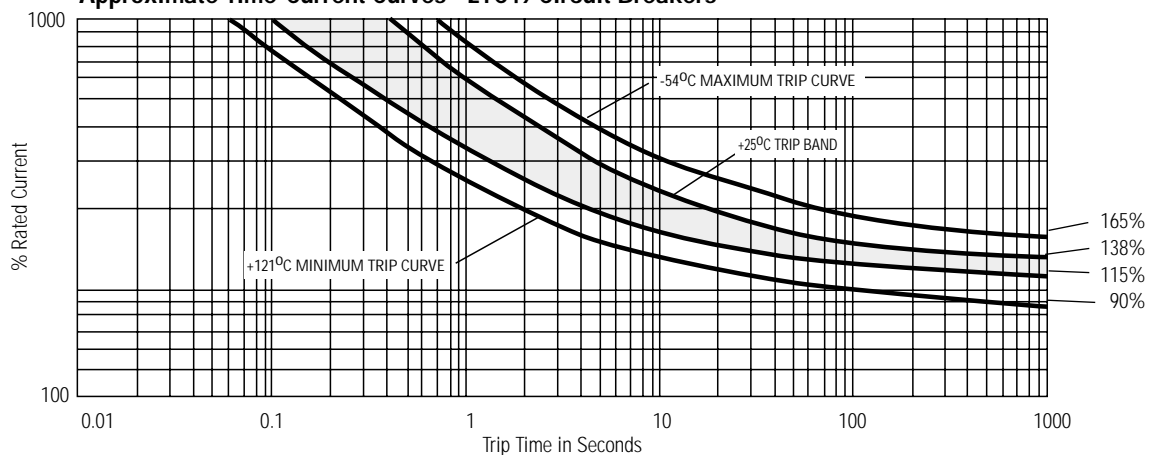

CONVERSION CHART	
INCHES	MM
.026	0.66
.036	0.91
.040	1.02
.055	1.40
.073	1.85
.083	2.11
.250	6.35
.352	8.94
.370	9.40
.380	9.65
.390	9.91
.400	10.16
.562	14.27
.704	17.88
.750	19.05
1.030	26.16
1.218	30.94
1.312	33.32

REVISIONS						
ZONE	LTR	2TC49	DESCRIPTION	PROJ. 1041	DATE	APPROVED
	L	SEE ECN		ECN0017504 PAF	8-20-04	D.A.

NOTES:

- EPOXY SURFACES ARE NON-DIMENSIONED. ENVELOPE DRAWING DIMENSIONS DO NOT APPLY TO THESE PROJECTED EPOXY SURFACES.
- TERMINAL AND MOUNTING HARDWARE MAY BE PACKAGED RATHER THAN INSTALLED.
- COUNTRY OF ORIGIN IS SHOWN FOR ILLUSTRATION PURPOSES ONLY. COUNTRY OF ORIGIN TO BE IDENTIFIED AS REQUIRED.
- DATE CODE PER 10588-285.
- MARK IN APPROXIMATE POSITION SHOWN IN BLACK INK PER 12506-70.

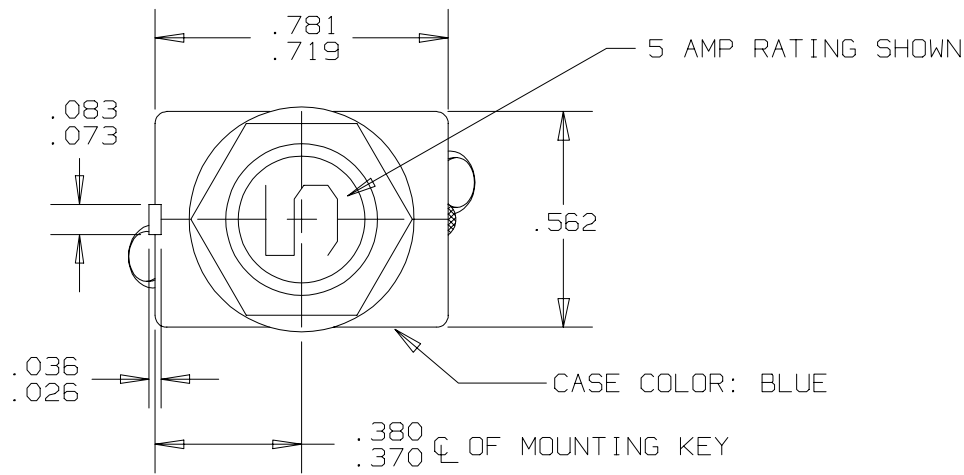

PERFORMANCE CHARACTERISTICS

DETAIL PERFORMANCE PER MIL-C-5809

OVERLOAD CYCLING	-----	100 CYCLES AT 200% RATING
VIBRATION	-----	10 G'S MINIMUM 50-500 HZ
MECHANICAL SHOCK	-----	50 G'S
ACCELERATION	-----	10 G'S
SAND AND DUST	-----	12 HOURS
CORROSION	-----	SALT SPRAY 50 HOURS
HUMIDITY	-----	10 DAYS
EXPLOSION PROOF	-----	WHILE INTERRUPTING RUPTURE CURRENTS
POST RUPTURE DIELECTRIC	-----	1125 VAC MIN. (1 MA)
POST LINK SEPARATION DIELECTRIC	-----	900 VAC MIN. (1 MA)

ENDURANCE:	120 VAC	400 HZ RESISTIVE	5000 CYCLES
	30 VDC	INDUCTIVE	2500 CYCLES
		RESISTIVE	5000 CYCLES
		INDUCTIVE	2500 CYCLES
		NO LOAD	10000 CYCLES

CALIBRATION:	2.5, 3, 5, 7.5 AND 10 AMP				
	MIN. ULT. TRIP	MAX. ULT. TRIP	200%	500%	1000%
+25°C, +77°F	115% RATING	138% RATING	5-20 SEC.	.5-2.0 SEC.	.12-.53 SEC.
-54°C, -65°F	115% RATING	165% RATING	7-40 SEC.	.6-3.0 SEC.	.16-.8 SEC.
+121°C, +250°F	90% RATING	138% RATING	3-13 SEC.	.33-1.1 SEC.	.07-.3 SEC.

RUPTURE:	2 1/2 AMP-----	120 VAC, 400	2800 AMPS.
	3 THRU 10 AMP-----	120 VAC, 400	2500 AMPS.
	2 1/2 THRU 10 AMP-----	28 VDC	6000 AMPS.

MAXIMUM OPERATING FORCES

PULL OUT	-----	5 LBS. MAX. (22.2 N)
RESET	-----	5 LBS. MAX. (22.2 N)

OPERATING ALTITUDE: 70,000 FT. (21,000 M)

WEIGHT: 25.0 GRAMS MAX.

VOLTAGE DROP:

2.5 AMP	-----	0.70 VOLTS MAX.
3 AMP	-----	0.55 VOLTS MAX.
5 AMP	-----	0.35 VOLTS MAX.
7.5 AMP	-----	0.30 VOLTS MAX.
10 AMP	-----	0.28 VOLTS MAX.

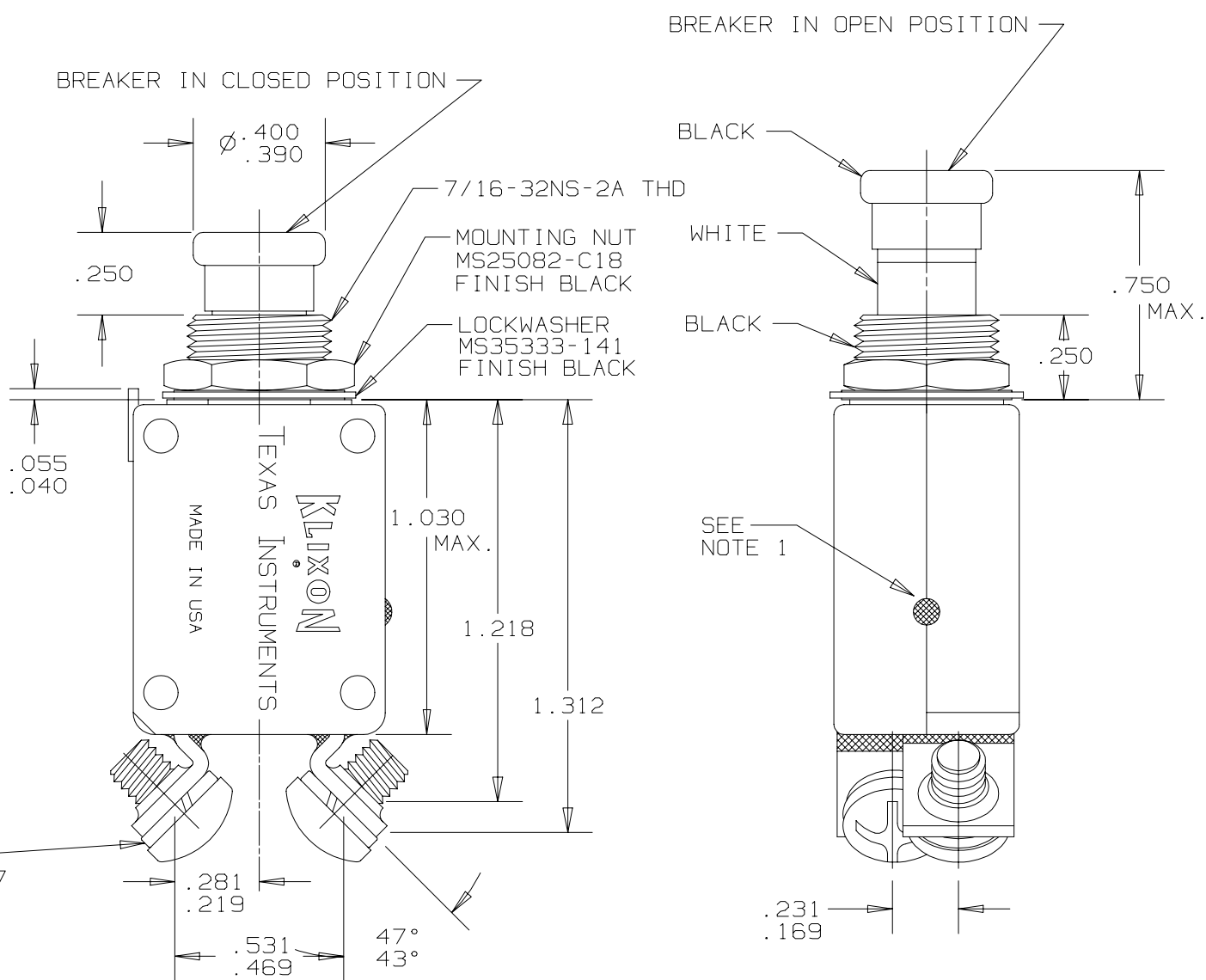

CIRCUIT BREAKER LINK SEPARATION CHARACTERISTICS
MAXIMUM CIRCUIT BREAKER LINK SEPARATION TIMES (IN SECONDS)
FOR LOCKED CONTACT CONDITION AS A FUNCTION OF OVERLOAD

	400%	500%	600%	700%	800%	900%	1000%
2 1/2	---	---	34.0	20.0	13.0	9.0	6.0
3	---	---	34.0	20.0	13.0	9.0	6.0
5	---	95.0	36.0	18.0	10.0	6.0	3.5
7 1/2	69.0	28.0	14.0	8.0	4.0	3.5	2.0
10	60.0	35.0	20.0	12.0	7.0	4.0	2.5

MARKING TABLE

T.I. PART NO.	MS PART NO.
2TC49-2 1/2	M5809/1-2 1/2
2TC49-3	M5809/1-3
2TC49-5	M5809/1-5
2TC49-7 1/2	M5809/1-7 1/2
2TC49-10	M5809/1-10

T.I. PART NO.
(I.E. 2TC49-5 SHOWN)

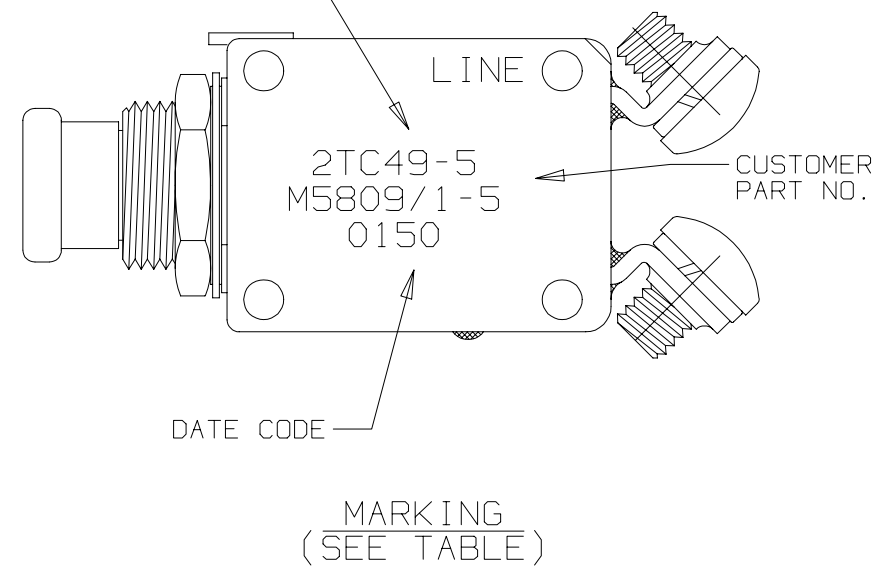

THIS IS A CAD DRAWING. THE GEOMETRY IN THE ASSOCIATED CAD COMPUTER FILE IS DIMENSIONALLY ACCURATE. WHEN DRAWING IS BEING REVISED, THE GEOMETRY MUST BE UPDATED IN ALL VIEWS AND ON ALL SHEETS.

UNLESS OTHERWISE SPECIFIED DIMENSIONS ARE IN INCHES	DRAWN H.H.	DATE 9-10-82	P2	03	P18
TOLERANCE ON FRACTIONS DECIMALS ANGLES	ENGINEER B.J.NM.	10-4-82	 TEXAS INSTRUMENTS ATTLEBORO, MASSACHUSETTS 02703 KLIXON CONTROL PRODUCTS DIVISION		
±.031	APPROVED N/A		TITLE PART NO. 2TC49 AMBIENT COMPENSATED, HIGH TEMP, CIRCUIT BREAKER PUSH-PULL, TRIP FREE ENVELOPE DRAWING		
MATERIAL	APPROVED H.HIRSHERUNER	9-27-82	SIZE C	CODE IDENT NO. 82647	2TC49
SIGNATURES ON FILE. REFER TO ELECTRONIC CHANGE NOTICE.			SCALE: 4X	SHEET 1 OF 1	