



# Three Phase TC Series Circuit Breakers

Miniature Ambient Compensated

## Features

- **One phase trips all**
- **Protective shields between each phase's terminals**
- **Pads increase mounting stability**
- **Also includes identical features as 2TC and 3TC**

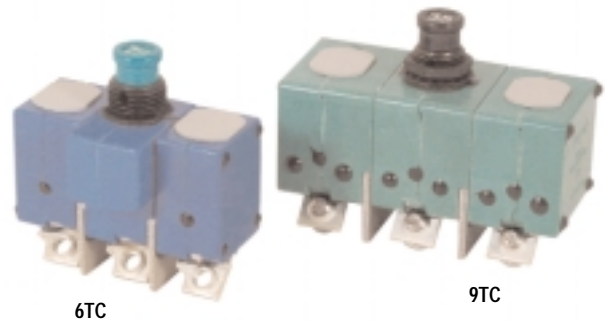

## Overview

The 6TC and 9TC circuit breakers provide ambient compensated circuit protection in a lightweight, subminiature package size. The three phase design integrates each individual phase to provide overcurrent protection in the event of simultaneous or unbalanced overloads, including short circuit conditions.

## Coordination

The 6TC and 9TC are compatible with their single phase 2TC and 3TC cousins. The 6TC and 9TC are available in ratings from 1-35 amps, with military and various commercial approvals on most styles.

## Ambient Temperature Compensation

The 6TC and 9TC are ambient compensated circuit breakers. This allows usage of smaller gauge wire.

The 6TC and 9TC can operate over a temperature range of  $-54^{\circ}\text{C}$  to  $121^{\circ}\text{C}$ , however, care should be taken to understand the specification limits at elevated ambient temperatures.

## Options\*

- Longer push buttons
- High vibration
- Metric mounting thread
- Metric terminal thread
- Dust boot†
- Auxiliary switch device available††

\* Contact factory for details

† Part Number 14500-1 fits 15/32 bushing  
Part Number 14500-5 fits 7/16 bushing

†† 6TC Device

## Trip Free

The complete line of TC series circuit breakers is trip free. The circuit breaker cannot be maintained closed during an overload, even with the actuator button held closed.

## High Short Circuit Capacity

For its miniature size, the 6/9TC series offers unusually high current interrupting capacity. Overloads up to 2000 amps at 120 VAC, 400 Hz can be safely interrupted without affecting calibration or operating performance in the standard 6/9TC series.

## Qualifications

MS14154	6TC2
MS14154L	6TC37
MS14154V	6TC63
MS14153	9TC2

European standards

SAE standards

All U.S. aircraft OEM's

Most European aircraft OEM's



4 3 2 1

REVISIONS					
ZONE	LTR	DESCRIPTION	PROJ. #1112	DATE	APPROVED
	T	ADDED ALL CODING AND MARKING INFORMATION; REDRAWN IN CADRA.	ECN0025548, DP	2-2-05	D.M.

PERFORMANCE CHARACTERISTICS

DETAIL PERFORMANCE PER MIL-C-5809

OVERLOAD CYCLING	100 CYCLES AT 200% RATING
VIBRATION	10 G'S MINIMUM 50-500 HZ
MECHANICAL SHOCK	25 G'S
ACCELERATION	10 G'S
SAND AND DUST	12 HOURS
CORROSION	SALT SPRAY 50 HOURS
HUMIDITY	10 DAYS
EXPLOSION PROOF	WHILE INTERRUPTING RUPTURE CURRENTS

ENDURANCE:	120 VAC	400 HZ INDUCTIVE	2500 CYCLES
MECHANICAL	400 HZ RESISTIVE	NO LOAD	5000 CYCLES

SINGLE * OR THREE PHASE CALIBRATION: 1 AMP, 15 AMP THRU 35 AMP					
	MIN. ULT. TRIP	MAX. ULT. TRIP	200%	500%	1000%
+25°C, +77°F	110% RATING	145% RATING	4-20 SEC.	.40-2.0 SEC.	.10-.53 SEC.
-54°C, -65°F	110% RATING	165% RATING	6-40 SEC.	.55-3.5 SEC.	.15-.80 SEC.
+71°C, +160°F	100% RATING	145% RATING	3-20 SEC.	.33-1.7 SEC.	.08-.40 SEC.

RUPTURE:	1 AMP, 15 AMP THRU 35 AMP	120 VAC, 400 HZ	2000 AMPS
----------	---------------------------	-----------------	-----------

MAXIMUM OPERATING FORCES	
PULL OUT	12 LBS. MAX. (53.4 N)
RESET	12 LBS. MAX. (53.4 N)

OPERATING ALTITUDE: 70,000 FT. (21,000 M)

WEIGHT/MASS: 110.0 GRAMS MAX. (0.242 LBS); 98 GRAMS NOMINAL (0.216 LBS).

VOLTAGE DROP:	
1 AMP	110 VOLTS MAX.
15 AMP	0.25 VOLTS MAX.
20 AMP	0.25 VOLTS MAX.
25 AMP	0.25 VOLTS MAX.
30 AMP	0.25 VOLTS MAX.
35 AMP	0.25 VOLTS MAX.

\* SINGLE PHASE MAXIMUM ULTIMATE TRIP VALUES APPLY WITH OTHER TWO PHASES CARRYING 100% OF RATED CURRENT.

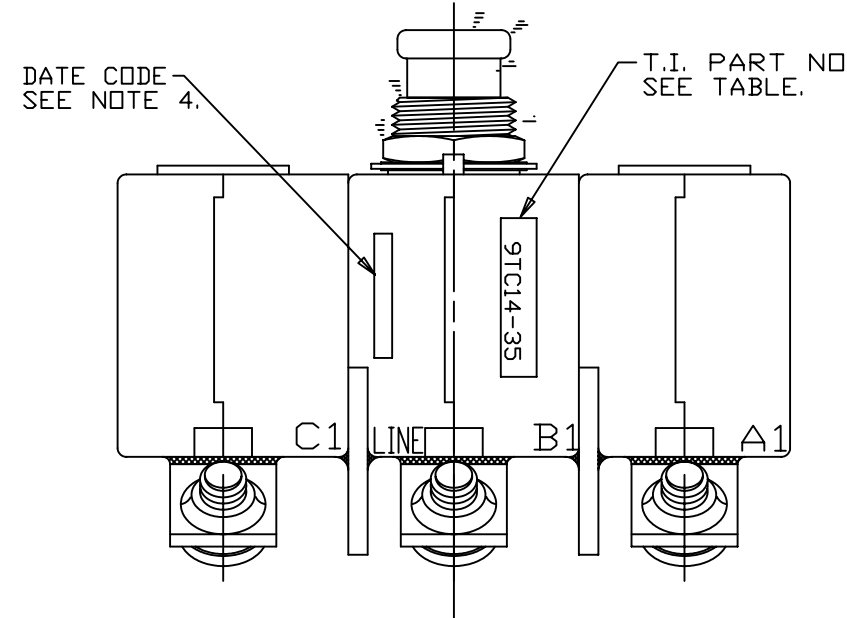
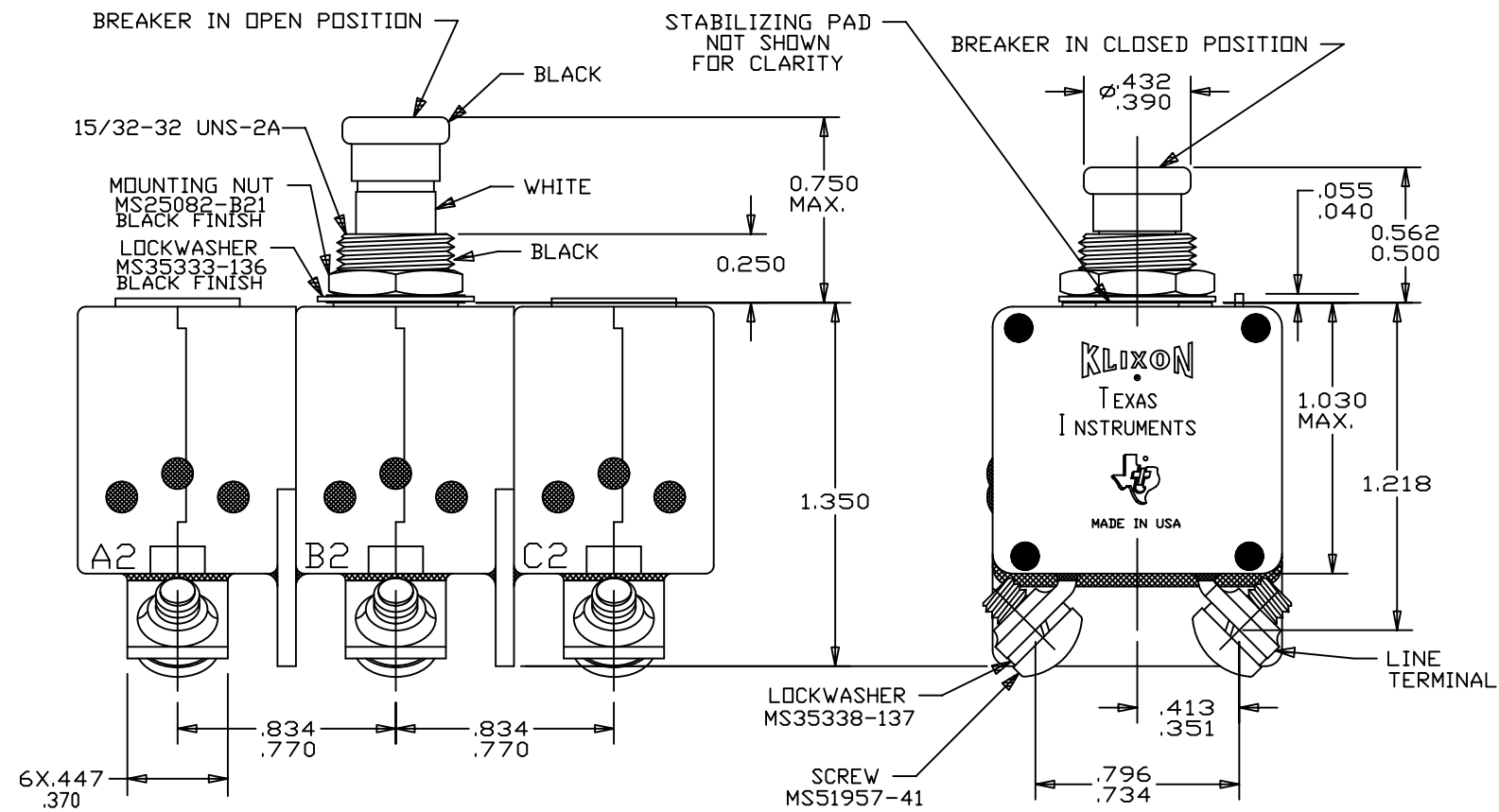
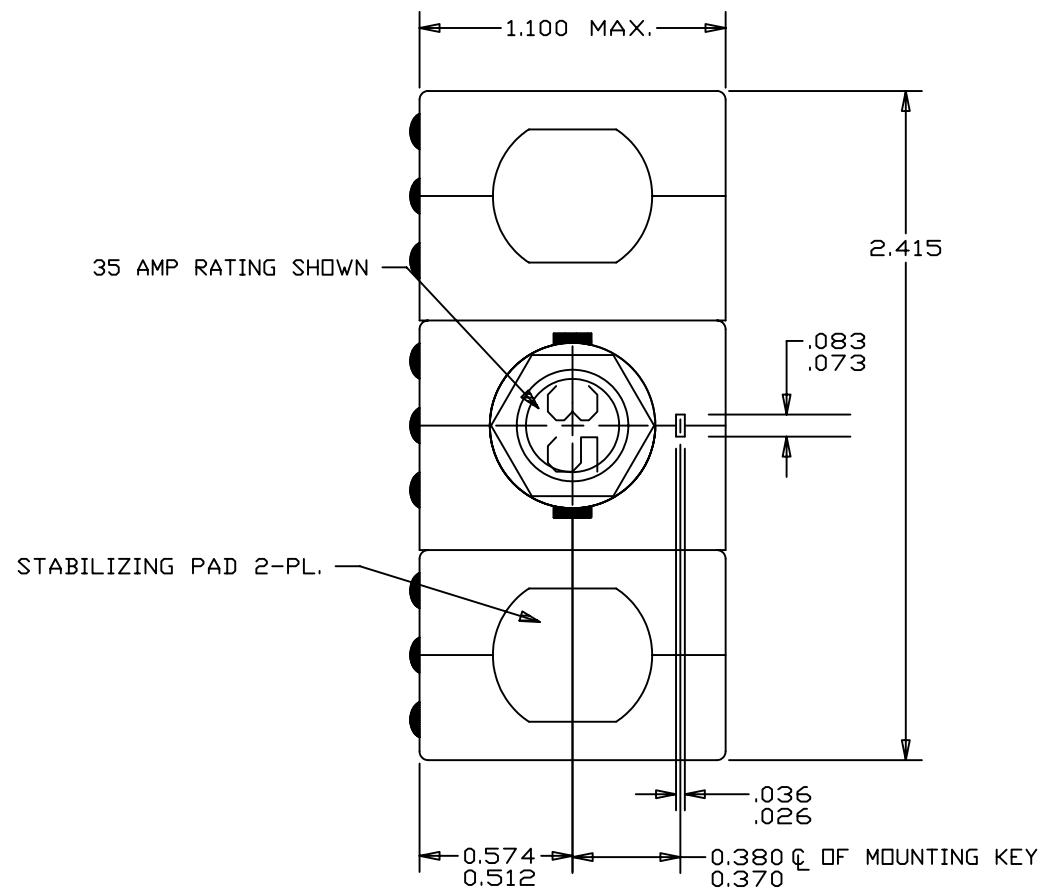

9TC14-35	35
9TC14-30	30
9TC14-25	25
9TC14-20	20
9TC14-15	15
9TC14-1	1
T.I. PART NO.	AMP

NOTES:

- EPOXY SURFACES ARE NON-DIMENSIONED. ENVELOPE DRAWING DIMENSIONS DO NOT APPLY TO THESE PROJECTED EPOXY SURFACES.
- TERMINAL AND MOUNTING HARDWARE MAY BE PACKAGED RATHER THAN INSTALLED.
- COUNTRY OF ORIGIN IS SHOWN FOR ILLUSTRATION PURPOSES ONLY. COUNTRY OF ORIGIN TO BE IDENTIFIED AS REQUIRED.
- DATE CODE PER 10588-285.
- ALL MARKINGS TO BE MADE IN APPROXIMATE POSITIONS SHOWN, WITH BLACK INK PER 12506-70; 3/32 INCH HIGH CHARACTERS.

THIS IS A CAD DRAWING. THE GEOMETRY IN THE ASSOCIATED CAD COMPUTER FILE IS DIMENSIONALLY ACCURATE. WHEN DRAWING IS BEING REVISED, THE GEOMETRY MUST BE UPDATED IN ALL VIEWS AND ON ALL SHEETS.

UNLESS OTHERWISE SPECIFIED DIMENSIONS ARE IN INCHES	DRAWN B. NICKERSON ENGINEER	DATE 2-11-70	Q3-1P18-1
TOLERANCE ON FRACTIONS DECIMALS ANGLES / ±.031 /	APPROVED T. BRASSARD APPROVED T. BRASSARD	2-11-70 2-11-70	TITLE PART NO. 9TC14 AMBIENT COMPENSATED, PUSH-PULL TRIP FREE CIRCUIT BREAKER ENVELOPE DRAWING
MATERIAL		SIZE C 82647	CODE IDENT NO. 9TC14
SIGNATURES ON FILE. REFER TO ELECTRONIC CHANGE NOTICE.		SCALE: 2:1	SHEET 1 OF 1

