

APV Series

Energy Storage DC Contactor

Specification

500 Amps / 900 Vdc



Certification information

Meet RoHS (2011/65/EU);

Application

COMPACT STRUCTURE, LOW NOISE

Contact design yields reduced unit size, low noise while carrying or switching current.

HIGH SAFETY

There is no arc leakage due to tight sealing.

HIGH CONTACT RELIABILITY

Stable contact resistance no matter how harsh the environment with sealed contacts

NO SPECIAL MOUNTING REQUIREMENT

Light weight actuator is less impacted by gravity with no special mounting orientation requirements.



Nomenclature

APV

—

A

B

A

A

Series code:
"APV" - APV Series

Mounting:
A:PCB,M8

Coil Voltage Code:
Standards Coils (w/Economizer):
"B" = 12 VDC,Internal Coil Suppression
"C" = 24 VDC,Internal Coil Suppression
"E" = 48 VDC,Internal Coil Suppression
"M" = 12-24 VDC PWM
"G" = 48 VDC PWM
"P" = 12-24 VDC
"Q" = 48 VDC

Coil Termination:
A:Flying leads 40cm(16in)
P:Pins(PCB)

Options (applied in this order) :
Blank = Std. Options (Without Aux.Contact Polarized Load Terminals)
"A" Normally Open without Aux. Contacts
"B" Normally Open with Aux. Contacts
"N" = Non-Polar Load Terminals

APV Series
Energy Storage DC Contactor
Specification
500 Amps / 900 Vdc



Performance Data:

Main Contact			Expected Life		
Contact Arrangement	1 Form X (SPST-NO)		Electrical Endurance	Break	250A@1000VDC 1000Cycle
Max. Switching Voltage	900 VDC			Make / Break	100A@1000VDC 50Cycle 50A@1000VDC 6000Cycle
Rated current	500A		Mechanical Life		200,000 Cycles
Max. Short Circuit Current	3000A@450VDC(1s)		AUX Contact		
Short Term Current			Aux Contact Arrangement	1 Form A	
Dielectric Withstanding Voltage (Initial)	Between Open Contacts	4000VDC 1mA 1min	Aux Contact Current Max	2A@30VDC/ 3A@125VAC	
	Between Contacts to Coil	2200VAC 1mA 1min	Aux Contact Current Min	100mA@8V	
Insulation Resistance (Initial)	Terminal to Terminal	Min 1000 MΩ	Aux. Contact Resistance Max.	0.417ohms@30VDC/ 0.150ohms@125VAC	
	Terminals to Coil	@1000Vdc			
Contact Resistance(initial)	Max. 10mΩ(1A 6V)				
Limit breaking	2000A@450VDC, 1 Cycle				
Environmental Data			Operate / Release Time		
Shock	Functional	196m/s ² Sine half-wave pluse	Operate Time (includes bounce)	30ms, Max. @20C	
	Destructive	490m/s ² Sine half-wave pluse			
Operating Temperature	-40~+85°C		Release Time	12ms, Max. @ 20C	
Humidity	5%~85%RH				
Weight	0.95Lb (0.43kg)				

APV Series
Energy Storage DC Contactor
Specification
500 Amps / 900 Vdc

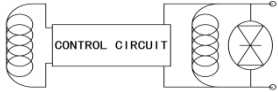

Coil Data at 20°C:

Coil Data							
Coil P/N Designation	B	C	E	M	G	P	Q
Nominal Voltage	12Vdc	24Vdc	48Vdc	12-24Vdc	48Vdc	12-24Vdc	48Vdc
Coil Type	Dual	Dual	Dual	PWM	PWM	External PWM	External PWM
Coil Voltage,Max(V)	16Vdc	32Vdc	64Vdc	36Vdc	72Vdc		
(Max.) Pick-up Voltage	8Vdc	16Vdc	40Vdc	9Vdc	32Vdc		
(Min.) Drop-out Voltage	0.5Vdc	2Vdc	4Vdc	6Vdc	18Vdc		
Pick-Up Current, Max (75 ms)	3.9A	1.6A	0.97A	3.8A	1.3A		
Coil Current	0.23A	0.097A	0.042A	0.13A	0.03A		
Coil Power	2.8W	2.3W	2W	2W	2W		
Internal Coil Suppression				N/A			
Coil Back EMF	55V	55V	125V	0V	0V		
Reverse Polarity	16V	32V	64V	100	100		

CURRENT CARRY RATINGS

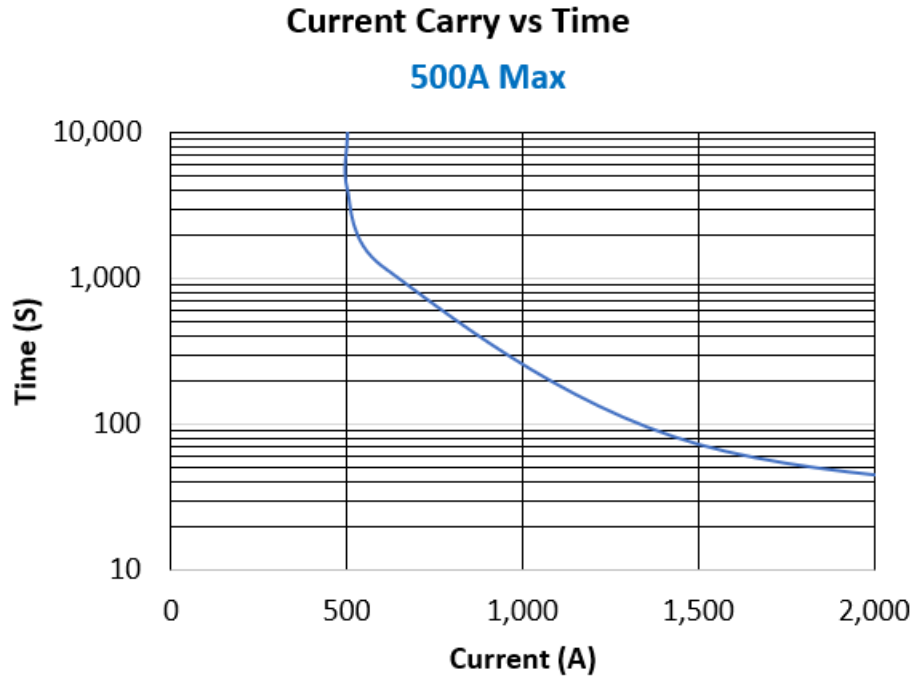

Auxiliary contacts

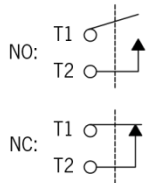

Power Contacts

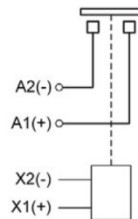

APV Series
Energy Storage DC Contactor
Specification
500 Amps / 900 Vdc



Performance Data:

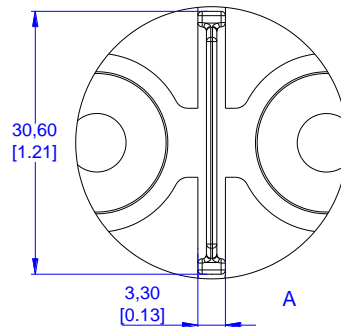
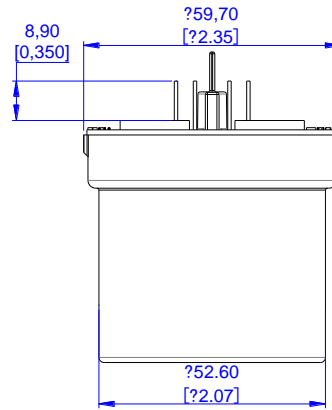
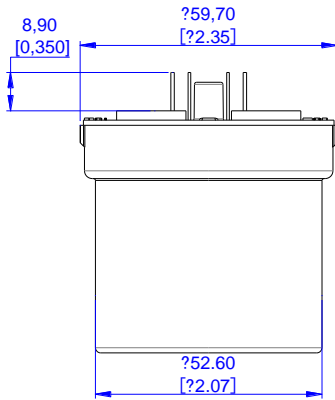
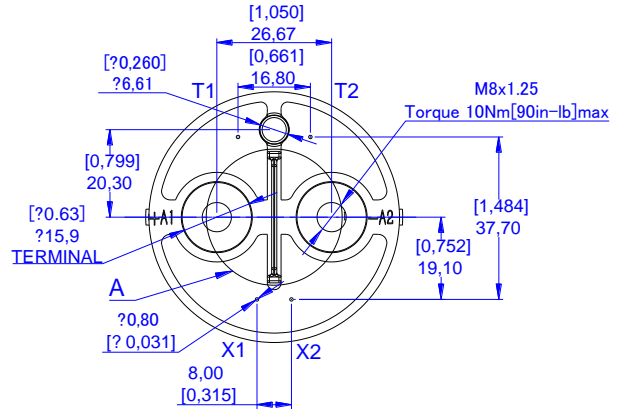
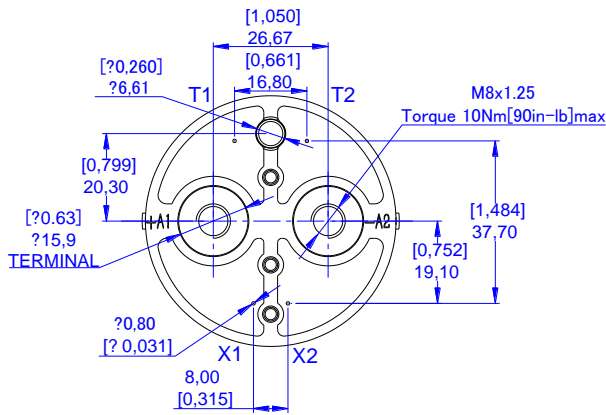

Application Note:

1. Be sure to use washer to prevent screws from loosening, all the terminals or copper bar must be in direct contact with the contactor's terminals.
Screw tightening torque is specified below. Exceeding the maximum torque can lead to product failure.
 - 8.8-11N.m
 - 1.7-3.3 N.m S
2. This is a polar product, please be sure to follow the product label for correct use. When the polarity of the load connection is
3. Products with circuit boards are already equipped with reverse surge absorption circuits, so there is no need to use surge protectors.
4. Avoid installing in a strong magnetic field (close to a transformer or magnet), or near a heat source.
5. The coil and contact of the relay are continuously energized, and the power supply is cut off and immediately connected. At this time, the resistance of the coil will increase due to the increase of the temperature of the coil, so that the suction voltage of the product will increase, which may lead to the excess of the rated suction voltage. In this case, the following measures should be taken: reduce the load current; Limit continuous power or use coil voltage higher than rated suction voltage.
6. When the voltage applied to both ends of the coil exceeds the maximum allowable applied voltage, the coil temperature may rise and lead to coil damage and inter-layer short circuit.
7. The rating in the contact parameters is the value at the time of the resistive load. When using an inductive load with $L/R > 1\text{ms}$, connect a surge current protection device in parallel with the inductive load. If no measures are taken, the electrical life may be degraded and the continuity may be poor. Please consider sufficient margin space in the design
8. Drive power must be greater than coil power or it will reduce performance capability.
9. Please do not allow debris and oil to adhere to the main lead end; Make sure that the external terminals are in reliable contact with the main outgoing end of the product, otherwise the temperature rise of the out-going end may be too high due to the excessive contact resistance.
10. The lead wire connected with the high voltage end of the product must have the corresponding current load capacity and heat dissipation capacity (it is recommended to use a copper bar with $\text{min } 50\text{mm}^2$), to prevent overheating affecting the life of the contactor.
11. After the products with energy saving panel are connected to the power supply, the circuit will automatically switch about 100ms later. Please do not repeat the on-off operation during this period, or the energy saving panel of contactor may be damaged.

12. Do not use if dropped.
13. Altran is impossible to determine all the performance parameters of relays in each specific application area, Therefore, customers should choose the products matching them according to their own conditions of use. If in doubt, contact Altran However, customer will responsible for what they chosen it is the user's responsibility to determine
14. Altran reserves the right to make changes. Customers should reconfirm the contents of the specification before first orders and ask for us to supply a new specification if necessary.