

# Rebling Datasheet

## 750 AMP XFT-STYLE FEED THROUGH TERMINAL

Our 750 amp XFT Style terminal has performance characteristics identical to our BFT Style 750 amp terminal but is specially designed for mounting onto thin or weak panels. The XFT Style 750 amp terminal's nickel-plated brass core stays cool at 750 amps of continuous current or for short term peaks of 4,000 amps. These terminals are designed for the temperature sensitive environment of lithium battery cells and the charging rates of ultracapacitors and supercapacitors. Equipping your power module with these watertight, single pole, wrench disconnect brass terminals will facilitate the incorporation of your modules into cutting edge GenSet, APU or Vehicle Electrification systems. Whether you are designing a liquid-cooled, pressurized battery pack for EV Mobility, a hazardous environment Generator Set or are simply bringing high current through a bulkhead of any thickness, our XFT Style 750 amp terminals, Covers and Accessories were designed with your application in mind.



### ELECTRICAL

Current (each of these current profiles causes a maximum 30°C temperature rise)

- ▶ Continuous Rated Current (CRC) (per IEC 61984 and UL1977) 750 amp
- ▶ Current Profile #2 - 50% CRC for 60min + 1 sec peak + 50% CRC for 60 min 4,000 amp
- ▶ Current Profile #3 - 50% CRC for 60min + 10 sec peak + 50% CRC for 60 min 3,000 amp
- ▶ Current Profile #4 - 50% CRC for 60min + 30 sec peak + 50% CRC for 60 min 1,800 amp
- ▶ Current Profile #5 - 50% CRC for 60min + 60 sec peak + 50% CRC for 60 min 1,500 amp

Voltage

- ▶ Rated Voltage (volts, continuous) 2,000
- ▶ Minimum Dielectric Withstanding Voltage (volts, AC or DC) 5,000

Contact Resistance Max (Micro Ohms) 70

### MECHANICAL

Wire Size Range

- ▶ Maximum Wire Size 750 MCM (380mm<sup>2</sup>)
- ▶ Terminal Only 4/0 (110mm<sup>2</sup>)
- ▶ With Flexible Cover 2.00
- ▶ Maximum Cable OD (inches) 0.80
- ▶ Terminal Only 0.80
- ▶ With Flexible Cover 0.025

Minimum Panel Thickness (inches) 0.025

Environmental Sealing

- ▶ With Standard Kit Components IP65
- ▶ With Optional Gasket IP68

Operating Temperature (C°)

- ▶ Terminal and Rigid Cover -40° to 125°
- ▶ Flexible Cover -40° to 90°

Flammability Rating (per UL94)

- ▶ Terminal V-0
- ▶ Flexible Cover V-0

Mechanical Shock

Vibration 50gs - 3 axes  
10gs - 3 axes

### CERTIFICATIONS

UL and CE Conformance  
RoHS Compliance

Certificates are downloadable from [Rebling.com](http://Rebling.com)  
All parts itemized on this datasheet are RoHS compliant

0.88 diameter brass conductor with two M10 tapped blind holes

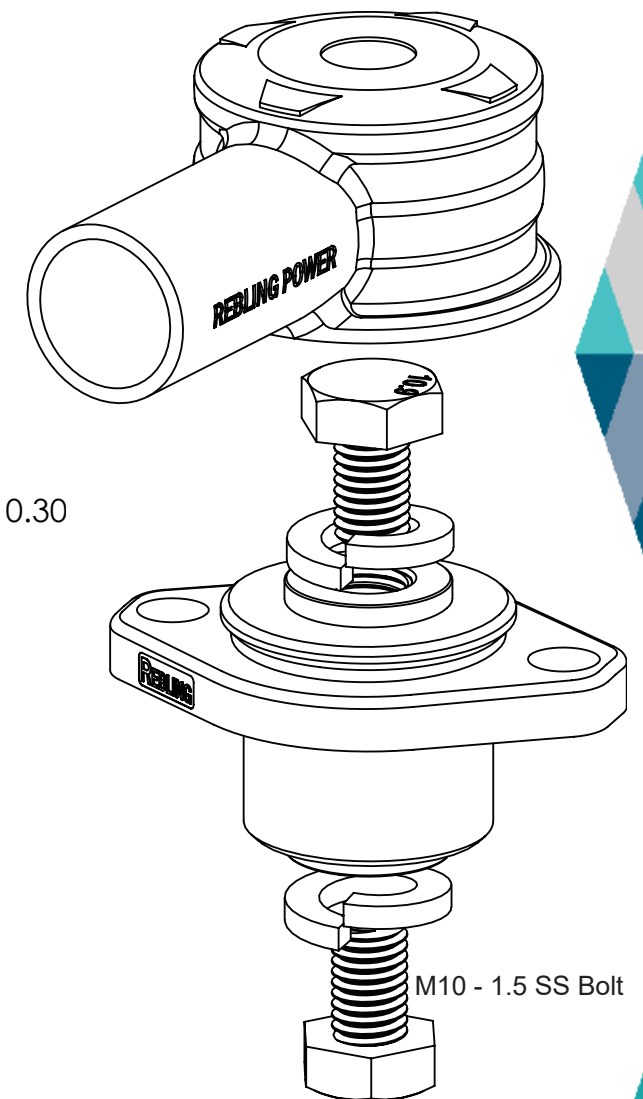
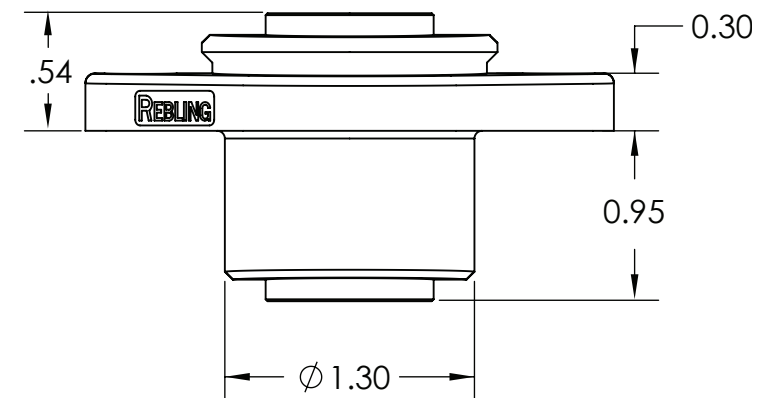
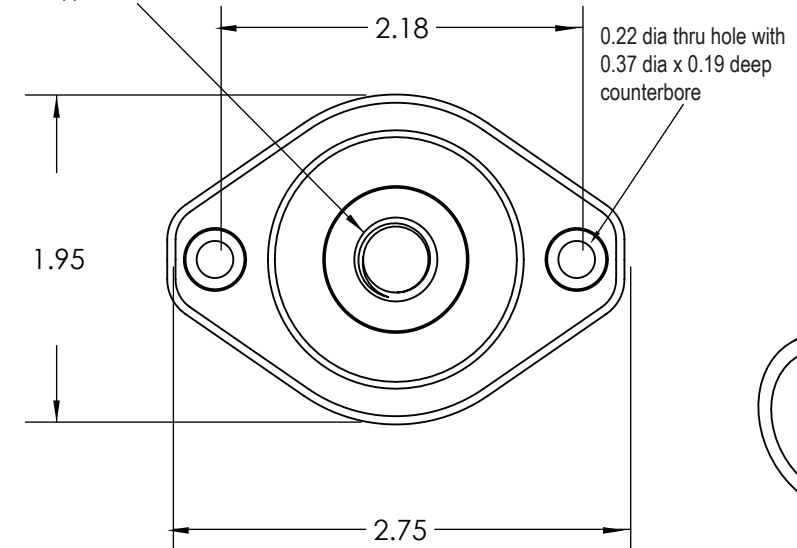

# Rebling Datasheet 750 AMP XFT-STYLE FEED THROUGH TERMINAL



P/N	Description*	Plastic Color	Weight (Grams)	Min Thick (mm)	UL 94 Rating	Plastic Material #
XFT-P-B	Terminal, Brass, Nickel plated	Black	195	2.5	5VA	000A1824
XFT-P-R	Terminal, Brass, Nickel plated	Red	195	2.5	5VA	000A1824
639A1830-B	Flexible Cover (0.82" ID)	Black	25	2.0	V-0	000A1825
639A1830-R	Flexible Cover (0.82" ID)	Red	25	2.0	V-0	000A1825
720A1817	Gasket for XFT Terminal	Black	4	2.0	V-0	000A1834

\*Terminal includes two 10mm bolts and two 10mm split washers



XFT Product Family

## MOUNTING and ASSEMBLY

Minimum Panel Thickness (inches)

Mounting Hole Pattern (see diagram)

Recommended Torque on Electrical Connection bolts

Recommended Torque on flat-bottomed panel mounting screws

Application Recommendations

▶ When using 4/0 cable with flexible cover, crimp lug to cable then push into cover using lubricant

▶ Panel Mount Hardware for IP68 (McMaster Carr)

▶ 92855A516

▶ 91828A241

▶ 9452K16

M5 stainless socket head screw

M5 stainless nut

M5 O-Ring

0.025

Three Circular Holes

60 to 80 in-lbs

5 to 8 in-lbs

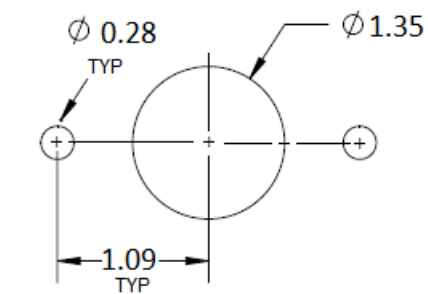

MOUNTING HOLE PATTERN (inches)