

Property of
Sensata Technologies

REVISIONS					
ZONE	LTR	DESCRIPTION	PROJ.# 1063	DATE	APPROVED
	D	1: ADDED WIRING DIAGRAM		8-1-95	S.B.M.
			CRM23747, CFF.		

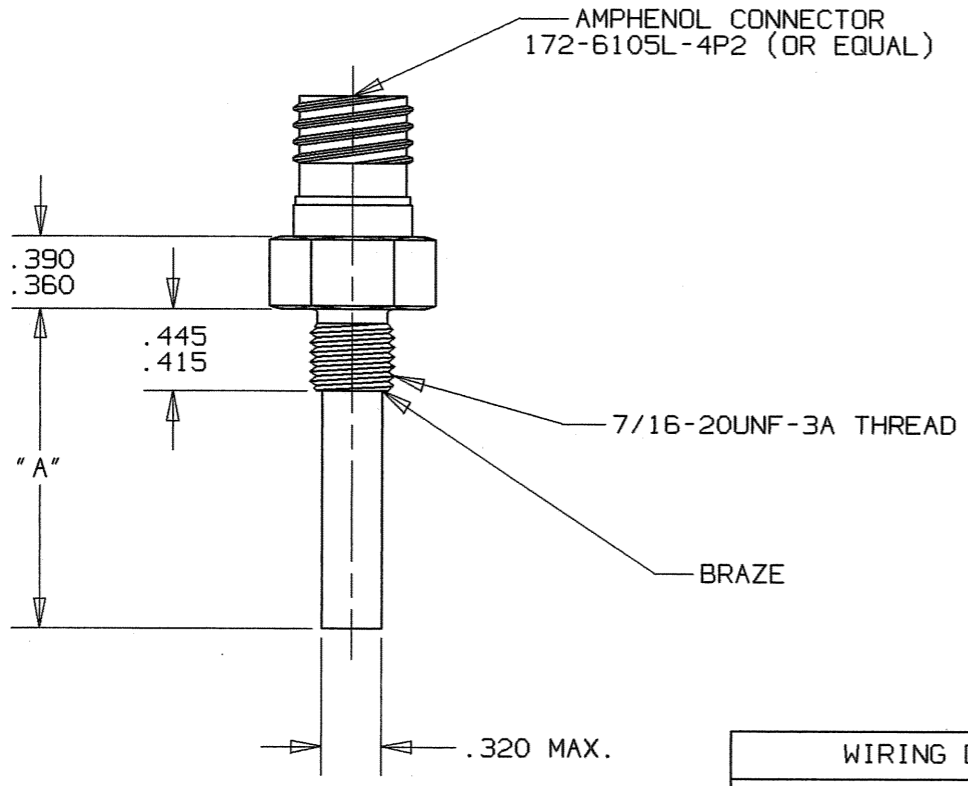
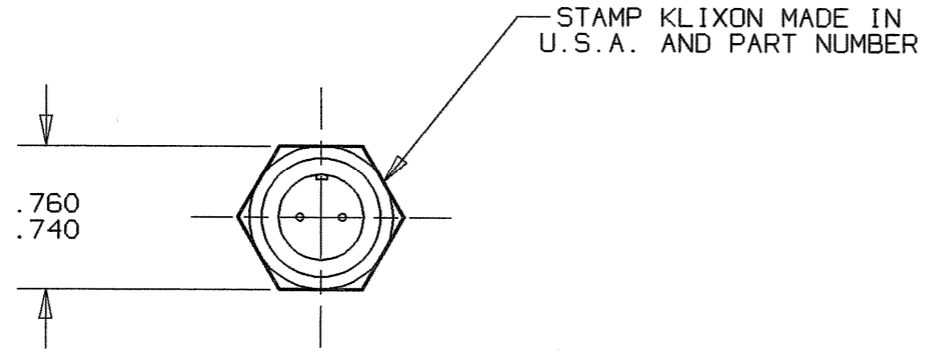

"A" AVAILABLE IN 1/2" INCREMENTS FROM .875" TO 4.00"
 OPERATING TEMPERATURES:
 OPEN ---°F ±---°F
 CLOSE ---°F ±---°F
 BASIC THERMOSTAT: 3BT TYPE
 MATERIAL: #300 SERIES STAINLESS STEEL

SUPERSEDES DWG. 21562 REV."C", DATED 7-7-67

WIRING DIAGRAM

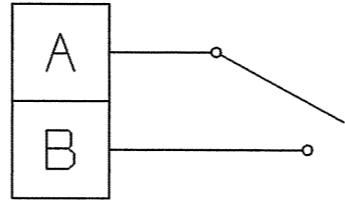

UNLESS OTHERWISE SPECIFIED DIMENSIONS ARE IN INCHES		DATE	Q4	P17	P1
DRAWN CHAS. FLEURANT		8-1-95	TEXAS INSTRUMENTS ATTLEBORO, MASSACHUSETTS 02703		
ENGINEER S.B. MARQUIS		8-1-95	KLIXON CONTROL PRODUCTS DIVISION		
APPROVED			TITLE		
APPROVED			STANDARD PROBE TYPE THERMOSTAT ENVELOPE DRAWING		
MATERIAL			SIZE	CODE IDENT NO.	
			B	82647	21562
SIGNATURES ON FILE. REFER TO ELECTRONIC CHANGE NOTICE.					

D

C

B

A

D

C

B

A